

LAMPIRAN 1

DAFTAR PERTANYAAN PENELITIAN

Bagian I merupakan pertanyaan yang berhubungan dengan identitas responden.

Nama	
Usia saat ini	tahun
Jenis Kelamin	a. <input type="checkbox"/> Laki-laki b. <input type="checkbox"/> Perempuan
Status Perkawinan	a. <input type="checkbox"/> Menikah b. <input type="checkbox"/> Belum Menikah
Pendidikan Terakhir	a. <input type="checkbox"/> SLTA b. <input type="checkbox"/> D3 c. <input type="checkbox"/> S1. d. <input type="checkbox"/> S2.
Masa Kerja	tahun
Unit Kerja	

Bagian II adalah pertanyaan mengenai Budaya Organisasi. Mohon berikan tanda (√) sesuai dengan pendapat Bapak / Ibu dengan keterangan sebagai berikut :

STS	TS	N	S	SS
Sangat tidak setuju	Tidak setuju	Netral	Setuju	Sangat setuju

No	Pertanyaan	STS	TS	N	S	SS
A. Keterlibatan						
1.	Dalam perusahaan ini, Informasi disebarakan secara luas sehingga setiap karyawan dapat memperoleh segala informasi yang mereka perlukan.					
2.	Saya bekerja dalam organisasi di perusahaan ini merasa menjadi bagian dari tim.					
3.	Organisasi/perusahaan ini terbangun atau terdiri dari tim-tim kerja.					
4.	Kemampuan orang-orang dalam perusahaan ini dipandang sebagai sumber yang penting untuk meningkatkan daya saing.					
B. Konsistensi						
5.	Para pemimpin dan manajer di perusahaan ini mengikuti pedoman-pedoman yang mereka buat untuk para anggotanya.					
6.	Perusahaan ini memiliki kode etik yang menjadi pedoman perilaku bagi karyawan dan memberikan pedoman tentang mana yang benar dan mana yang salah.					
7.	Ketika terjadi ketidak-sepakatan, kami di perusahaan ini bekerja keras untuk mencari penyelesaian yang menguntungkan bagi semua pihak yang tadinya tidak sepakat.					
8.	Di perusahaan ini mudah mencapai konsensus, meskipun menyangkut isu-isu (masalah-masalah) yang sulit.					
9.	Koordinasi untuk proyek-proyek yang melibatkan berbagai unit dalam perusahaan ini mudah dilakukan.					
10.	Di perusahaan ini terdapat keselarasan dari tujuan-tujuan pada berbagai tingkatan (level) Jabatan.					
C. Adaptabilitas						

11.	Perusahaan ini merespon dengan baik terhadap pesaingnya dan perubahan-perubahan lingkungan bisnis.					
12.	Perusahaan ini secara terus menerus mengadopsi dan meningkatkan cara-cara baru untuk melaksanakan pekerjaan.					
13.	Komentar-komentar dan saran-saran dari pelanggan seringkali menjadi pertimbangan untuk perubahan dalam Perusahaan ini.					
14.	Masukan atau saran dari pelanggan secara langsung mempengaruhi keputusan-keputusan dalam Perusahaan ini.					
15.	Manajemen di perusahaan ini memandang kegagalan sebagai kesempatan untuk pembelajaran dan pengembangan diri.					
16.	Kami melakukan koordinasi tentang kegiatan-kegiatan dari berbagai unit kerja dalam Perusahaan ini.					
D. Misi						
17.	Perusahaan ini memiliki misi yang jelas yang memberikan makna dan arah dari pekerjaan yang kami lakukan.					
18.	Perusahaan ini memiliki strategi yang jelas tentang masa depan Organisasi/Perusahaan.					
19.	Terdapat kesepakatan yang meluas dalam organisasi tentang tujuan-tujuan Perusahaan ini.					
20.	Di Perusahaan ini, para pemimpin dengan jelas menyatakan tujuan-tujuan yang ingin kami capai.					
21.	Visi Perusahaan ini menciptakan semangat dan motivasi bagi para karyawan.					

Bagian III adalah pertanyaan mengenai Gaya Kepemimpinan Transformasional. Mohon berikan tanda (√) sesuai dengan pendapat anda dengan keterangan sebagai berikut :

STS	TS	N	S	SS
Sangat tidak setuju	Tidak setuju	Netral	Setuju	Sangat setuju

No	Pertanyaan					
A. Pengaruh Ideal / Behavioral						
1.	Atasan saya membicarakan nilai-nilai dan kepercayaan-kepercayaan yang paling penting baginya.					
2.	Atasan saya menjelaskan/menunjukkan pentingnya memiliki perasaan terhadap suatu tujuan yang kuat.					
3.	Atasan saya mempertimbangkan konsekuensi moral dan etika dalam mengambil keputusan.					
4.	Atasan saya menekankan pentingnya perasaan memiliki misi bersama.					
B. Pengaruh Ideal / Attributed						
5.	Merupakan suatu kebanggaan bagi saya bisa bekerja sama dengan atasan saya saat ini.					
6.	Atasan saya tidak mementingkan diri sendiri, melainkan melakukan segala sesuatu demi kebaikan group atau kelompok.					
7.	Atasan saya bertindak dengan cara yang membuat saya merasa respek kepadanya.					
8.	Atasan saya menunjukkan suatu perasaan yang kuat dan penuh percaya diri.					
C. Motivasi Inspirasional						
9.	Atasan saya berbicara optimistis berkaitan tentang masa depan.					
10.	Atasan saya berbicara dengan antusias mengenai apa yang mesti diselesaikan.					
11.	Atasan saya menunjukkan keyakinan bahwa tujuan-tujuan akan tercapai.					
C. Stimulasi Intelektual						
12.	Atasan saya mencari perspektif yang berbeda ketika menyelesaikan permasalahan.					

13.	Atasan saya memberi kesempatan kepada saya untuk melihat permasalahan dari berbagai sudut pandang.					
14.	Atasan saya mengusulkan cara-cara baru untuk mencari cara bagaimana menyelesaikan tugas.					
D. Pertimbangan Individual						
15.	Atasan saya meluangkan waktu untuk mengajari dan memberi bimbingan (coaching) kepada bawahan.					
16.	Atasan saya membantu saya untuk mengembangkan kekuatan-kekuatan yang saya miliki.					
17.	Atasan saya mempertimbangkan bahwa saya memiliki kebutuhan-kebutuhan yang berbeda, kemampuan yang berbeda, dan aspirasi yang berbeda dengan yang lain.					



Bagian IV adalah pertanyaan mengenai Kepuasan Kerja. Mohon berikan tanda (√) sesuai dengan pendapat anda dengan keterangan sebagai berikut :

STS	TS	N	S	SS
Sangat tidak setuju	Tidak setuju	Netral	Setuju	Sangat setuju

No	Pertanyaan	STS	TS	N	S	SS
A. Pekerjaan						
1.	Pekerjaan saya sesuai dengan minat dan pengetahuan yang saya miliki .					
2.	Saya merasa senang melakukan pekerjaan di perusahaan tempat saya bekerja sekarang.					
3.	Pekerjaan saya membuat saya merasa tertantang untuk lebih maju.					
B. Atasan						
4.	Atasan saya cakap dalam mengambil keputusan.					
5.	Atasan saya berlaku adil dalam memberikan penilaian atas prestasi kerja anak buahnya.					
6.	Atasan saya tegas dalam menegakkan disiplin kerja.					
C. Teman Kerja						
7.	Terdapat kondisi persaingan yang sehat di perusahaan tempat saya bekerja.					
8.	Para karyawan di perusahaan ini saling menghormati hak-hak individu satu sama lain.					
9.	Di perusahaan ini terdapat kekompakan bekerja sama yang baik dalam tim .					
D. Karier / Promosi						
10.	Kebijakan promosi untuk kenaikan jabatan di perusahaan ini dilaksanakan dengan fair (adil).					
11.	Promosi atau kenaikan jabatan di perusahaan ini dilaksanakan secara obyektif.					
12.	Promosi untuk kenaikan jabatan di perusahaan ini didasarkan pada prestasi kerja.					
E. Gaji / Upah						

13.	Gaji tetap yang saya terima sesuai dengan tingkat kemampuan saya.					
14.	Besarnya tunjangan yang saya terima sesuai dengan besarnya tanggungjawab yang saya pikul.					
15.	Macam tunjangan yang saya terima sesuai dengan tingkat pendidikan saya.					
F. Lingkungan / Suasana Kerja						
16.	Perusahaan ini menyediakan ruangan kerja yang memadai dan nyaman.					
17.	Perusahaan ini menyediakan alat bantu kerja yang memadai untuk kebutuhan tugas saya.					
18.	Perusahaan ini menyediakan layanan kesehatan bagi para karyawan yang memerlukannya.					

Bagian V adalah pertanyaan mengenai Kinerja Karyawan. Mohon berikan tanda (√) sesuai dengan pendapat anda dengan keterangan sebagai berikut :

STS	TS	N	S	SS
Sangat tidak setuju	Tidak setuju	Netral	Setuju	Sangat setuju

No	Pertanyaan					
A. Kualitas Kerja						
1.	Saya mempersiapkan dan melaksanakan tugas dengan baik sehingga jarang sekali terjadi kesalahan/kegagalan.					
2.	Hasil kerja saya berkualitas baik karena saya memperhatikan aspek <i>quality control</i> secara cermat.					
3.	Klien kami merasa puas dengan kualitas hasil kerja saya di perusahaan ini.					
B. Efisiensi						
4.	Dalam bekerja saya berpikir untuk melaksanakan tugas dengan jumlah sumber daya minimal dan hasil kerja maksimal.					
5.	Dalam bekerja di perusahaan ini saya sangat memperhatikan aspek-aspek penghematan biaya operasional.					

	C. Kemampuan Karyawan					
6.	Sebagai karyawan di perusahaan ini saya memiliki kemampuan yang dapat diandalkan untuk menyelesaikan pekerjaan.					
7.	Kemampuan karyawan di perusahaan ini cukup merata antara satu dengan yang lainnya dalam sebuah tim kerja.					
8.	Saya sebagai karyawan di perusahaan ini mampu melakukan <i>problem solving</i> dengan baik ketika terjadi masalah.					
	D. Ketepatan Waktu					
9.	Sebagai karyawan di perusahaan ini saya memulai proses kerja pada waktu yang tepat sesuai dengan rencana dan peraturan yang ada.					
10.	Durasi proses produksi disini selalu tepat waktu sesuai dengan rencana sehingga tidak pernah mengganggu jadwal kegiatan program acara yang lain.					
	E. Pengetahuan Karyawan					
11.	Sebagai karyawan di perusahaan ini saya memiliki pengetahuan yang cukup untuk melaksanakan pekerjaan sehari-hari.					
12.	Setiap ada perkembangan teknologi terkait pekerjaan saya, saya selalu menyesuaikan diri dengan mengikuti pelatihan-pelatihan.					
	F. Kreativitas					
13.	Sebagai karyawan di perusahaan ini saya selalu berkreasi untuk mencari cara-cara baru dalam menyelesaikan tugas.					
14.	Kreativitas saya sebagai karyawan di perusahaan ini cukup menonjol untuk inovasi produk yang lebih menarik.					
	G. Melaksanakan Tugas Sesuai Prosedur					
15.	Sebagai karyawan di perusahaan ini saya menjalankan tugas sesuai <i>Standard Operating Procedure</i> / SOP yang telah ditetapkan.					
16.	Sebagai karyawan di perusahaan ini saya mencatat dan mendokumentasikan langkah-langkah proses kerja Operasional sehari-hari.					

LAMPIRAN 2
REKAPITULASI DATA

NO	BUDAYA ORGANISASI								
	Keterlibatan		Konsistensi		Adaptabilitas			Misi	
	X1.1	X1.2	X1.3	X1.4	X1.5	X1.6	X1.7	X1.8	X1.9
1	4	4	2	3	3	3	3	3	3
2	4	4	4	4	4	4	2	4	4
3	4	4	4	4	4	4	4	4	4
4	4	4	5	4	3	4	4	4	4
5	4	4	4	4	4	4	4	4	4
6	5	4	4	4	3	4	4	3	4
7	4	4	4	3	4	4	3	3	4
8	4	4	4	3	4	4	3	3	4
9	4	4	4	3	4	4	3	3	4
10	4	4	4	3	4	4	3	3	4
11	4	4	4	3	4	4	3	3	4
12	4	4	4	3	4	4	3	3	4
13	4	4	4	3	4	4	3	3	4
14	4	4	4	4	4	4	3	2	4
15	4	4	4	3	4	4	3	3	4
16	5	3	4	3	4	4	3	3	4
17	4	4	4	3	4	4	3	3	4
18	4	4	4	3	4	4	3	2	4
19	4	4	4	3	4	4	3	3	4
20	4	4	4	3	4	4	3	3	4
21	3	5	4	3	4	4	3	3	4
22	4	4	4	3	4	4	4	5	5
23	5	3	1	1	1	1	1	3	1
24	4	4	4	3	4	4	3	3	4
25	4	4	4	3	4	4	3	2	4
26	4	4	4	3	4	4	3	3	4
27	3	3	4	3	4	4	3	3	4
28	4	4	4	4	4	4	3	3	4
29	4	4	4	3	4	4	3	3	4
30	4	4	4	3	4	4	3	3	4
31	3	4	4	3	4	4	3	3	4
32	4	4	4	3	4	4	3	3	4

NO	BUDAYA ORGANISASI								
	Keterlibatan		Konsistensi		Adaptabilitas			Misi	
	X1.1	X1.2	X1.3	X1.4	X1.5	X1.6	X1.7	X1.8	X1.9
33	4	4	3	3	3	4	4	3	4
34	5	4	3	4	3	4	3	4	5
35	3	4	3	5	4	4	4	3	3
36	2	4	4	4	4	4	3	3	1
37	4	5	4	2	4	3	3	3	3
38	3	5	4	4	4	4	3	4	3
39	4	4	2	3	2	2	2	2	3
40	4	4	2	2	1	2	2	2	2
41	3	4	3	3	4	4	3	3	4
42	4	4	1	1	1	1	1	1	1
43	4	4	3	4	3	4	4	3	3
44	4	4	4	3	4	4	4	4	3
45	4	4	4	4	3	3	4	3	3
46	4	4	3	4	2	4	2	4	4
47	4	4	3	4	2	4	2	4	4
48	5	5	4	4	5	4	4	4	5
49	4	4	2	3	3	3	3	3	3
50	4	5	3	3	2	2	5	4	4
51	4	4	4	2	2	4	2	3	2
52	4	4	4	4	4	4	3	3	4
53	4	4	2	2	1	1	2	2	2
54	3	4	4	2	2	2	3	2	3
55	2	2	2	2	2	2	2	2	2
56	4	4	2	2	2	2	2	2	2
57	3	4	2	2	2	2	2	2	2
58	4	4	2	2	2	2	2	2	2
59	4	5	4	4	5	3	3	3	4
60	4	4	4	2	5	4	4	5	5
61	4	3	3	4	3	3	3	4	4
62	3	4	4	3	2	3	4	4	4
63	4	4	4	4	5	3	4	4	3
64	4	5	4	3	4	4	3	3	3

NO	BUDAYA ORGANISASI								
	Keterlibatan		Konsistensi		Adaptabilitas			Misi	
	X1.1	X1.2	X1.3	X1.4	X1.5	X1.6	X1.7	X1.8	X1.9
65	4	4	3	3	3	3	3	4	4
66	2	2	2	2	2	2	2	2	2
67	4	4	2	2	2	2	2	2	2
68	4	4	3	3	3	4	2	1	3
69	2	2	2	2	2	2	2	2	2
70	4	4	2	2	3	5	5	4	4
71	4	3	3	2	2	4	4	2	2
72	2	4	5	2	2	2	2	2	2
73	3	4	4	4	4	3	3	4	2
74	4	4	4	4	2	4	3	3	4
75	4	3	4	3	4	4	3	3	4
76	4	5	3	2	2	3	2	1	2
77	4	4	4	3	4	3	4	3	4
78	4	4	4	3	4	4	3	3	4
79	4	4	4	3	4	4	3	3	4
80	4	4	4	3	4	4	3	3	4
81	3	3	4	4	4	3	3	4	3
82	2	3	3	3	3	3	3	3	3
83	3	4	3	2	2	3	2	3	4
84	4	4	3	4	3	3	4	3	3
85	3	4	3	3	4	3	4	3	3
86	3	3	3	3	3	4	3	4	3
87	3	4	4	2	2	3	3	3	3
88	3	3	3	3	4	3	4	4	4
89	3	3	2	3	3	4	3	4	4
90	4	4	3	4	3	4	3	5	4
91	3	2	3	2	2	3	2	3	3
92	2	3	2	2	3	3	2	3	3
93	3	2	2	3	2	2	3	3	3
94	3	4	4	4	4	3	4	4	4
95	4	3	4	3	4	3	4	5	4
96	4	3	3	4	3	4	3	5	4

NO	BUDAYA ORGANISASI								
	Keterlibatan		Konsistensi		Adaptabilitas			Misi	
	X1.1	X1.2	X1.3	X1.4	X1.5	X1.6	X1.7	X1.8	X1.9
97	3	4	3	3	4	3	4	4	5
98	3	3	3	3	2	3	3	4	4
99	3	2	2	2	3	3	3	3	3
100	4	3	4	4	4	4	3	4	5
101	3	4	3	3	3	3	4	3	4
102	3	4	4	4	4	3	4	4	5
103	4	5	4	4	5	4	5	4	4
104	4	4	3	3	4	3	4	4	5
105	3	3	3	3	3	2	3	3	4
106	4	4	4	5	4	5	5	4	4
107	4	3	5	5	5	4	5	4	4
108	3	4	3	4	3	4	4	5	4
109	4	4	5	5	4	5	4	5	5
110	4	3	5	5	4	5	5	5	4
111	3	4	5	4	5	4	3	5	5
112	4	3	5	4	4	4	5	4	4
113	4	4	5	4	4	4	4	4	4
114	3	3	3	3	2	3	2	4	3
115	5	4	5	4	4	4	4	4	4
116	3	3	3	2	3	3	3	3	4
117	2	2	3	3	3	2	2	4	3
118	4	3	3	4	4	5	4	5	4
119	5	5	4	4	5	4	5	4	4
120	3	4	5	4	4	3	4	5	5
121	3	4	4	4	4	4	4	4	5
122	3	4	3	3	3	4	3	5	4
123	4	3	5	5	4	3	4	4	4
124	3	3	4	4	3	3	4	3	4
125	4	5	5	4	5	4	4	4	4
126	5	5	4	4	4	3	4	4	4
127	4	4	4	4	4	4	3	4	4
128	3	3	3	3	3	4	4	3	4

NO	BUDAYA ORGANISASI								
	Keterlibatan		Konsistensi		Adaptabilitas			Misi	
	X1.1	X1.2	X1.3	X1.4	X1.5	X1.6	X1.7	X1.8	X1.9
129	3	3	4	3	4	4	3	4	4
130	3	4	3	4	4	3	4	5	4
131	3	4	4	4	4	5	5	4	5
132	4	4	5	5	4	5	4	4	4
133	5	5	5	5	5	4	5	4	5
134	4	4	3	3	4	4	3	5	5
135	5	5	5	4	5	4	4	4	4
136	4	5	4	5	4	5	5	5	5
137	4	4	3	4	3	4	4	4	5
138	4	4	3	4	4	4	4	4	4
139	4	4	4	3	4	5	5	4	4
140	5	4	4	4	5	4	4	4	5
141	4	4	4	3	3	4	4	4	5
142	3	3	3	4	4	4	3	4	4
143	4	4	5	4	5	4	4	5	5
144	4	4	4	4	4	4	3	4	5
145	3	4	4	4	4	3	4	4	5
146	4	5	4	5	5	4	5	5	4
147	4	5	4	4	5	4	5	5	5
148	4	4	3	4	4	4	4	4	4
149	4	4	4	3	4	4	4	5	5
150	3	4	4	4	4	4	4	4	4
151	4	4	3	5	3	4	4	3	4
152	4	3	4	5	4	4	4	5	4
153	4	5	4	4	5	3	4	5	4
154	5	4	4	3	4	5	5	4	3
155	5	4	4	3	4	4	4	4	3
156	4	4	4	4	4	4	5	4	4
157	5	5	4	5	4	3	4	5	4
158	4	4	4	3	4	4	3	4	3
159	4	4	4	4	4	3	4	5	4
160	3	3	4	4	4	4	3	4	4

NO	BUDAYA ORGANISASI								
	Keterlibatan		Konsistensi		Adaptabilitas			Misi	
	X1.1	X1.2	X1.3	X1.4	X1.5	X1.6	X1.7	X1.8	X1.9
161	5	5	5	5	5	4	3	4	3
162	4	4	5	4	4	3	4	5	4
163	5	3	3	3	3	4	3	3	4
164	4	3	5	4	3	4	4	3	4
165	4	3	5	5	5	4	5	4	4
166	3	4	3	4	3	4	4	5	4
167	4	4	5	5	4	5	4	5	5
168	4	4	3	3	4	3	4	4	5
169	3	4	5	4	5	4	3	5	5
170	4	3	5	3	4	4	5	4	4
171	4	3	5	5	4	5	5	5	4
172	3	3	3	3	4	3	4	4	3
173	4	4	4	5	4	5	5	4	4
174	4	4	5	4	5	4	5	3	4
175	4	4	5	4	5	4	4	4	5
176	4	4	5	4	4	5	4	5	5
177	5	4	5	4	4	4	4	4	4
178	5	4	3	3	4	4	4	5	4
179	5	5	4	4	5	4	5	4	4
180	4	4	5	4	4	4	4	4	4
181	4	3	3	4	4	5	4	5	4
182	3	3	4	4	4	4	4	4	4
183	3	4	5	4	4	3	4	5	5
184	3	4	4	5	4	4	3	3	4
185	5	4	5	4	3	3	3	3	3
186	4	4	5	5	4	3	4	3	3
187	3	3	5	5	3	4	3	3	4
188	4	3	4	4	3	3	3	3	4
189	4	4	5	4	5	3	4	4	3
190	4	4	4	3	3	4	3	3	4
191	3	4	4	4	3	3	4	4	3
192	3	4	3	3	3	4	4	3	4

NO	BUDAYA ORGANISASI								
	Keterlibatan		Konsistensi		Adaptabilitas			Misi	
	X1.1	X1.2	X1.3	X1.4	X1.5	X1.6	X1.7	X1.8	X1.9
193	4	4	3	3	4	3	4	4	4
194	5	5	5	5	4	5	5	3	4
195	3	3	3	4	4	4	5	4	4
196	4	5	4	4	5	5	5	3	3
197	4	5	4	5	5	4	5	4	4
198	4	5	5	3	5	4	4	5	4
199	5	5	4	5	5	4	5	4	5
200	4	5	4	4	3	5	5	3	4
201	4	4	4	4	4	4	3	4	4
202	5	5	4	4	4	5	5	4	3
203	3	3	3	3	2	3	4	3	4
204	5	4	3	4	3	3	4	3	4
205	4	3	4	4	3	4	5	4	4
206	5	4	5	5	4	5	5	3	4
207	4	5	4	4	5	3	4	4	3
208	4	4	4	4	4	5	5	4	4
209	3	3	3	3	3	4	4	4	3
210	4	5	4	4	4	5	5	4	4
211	4	4	3	4	3	3	4	3	4
212	5	5	5	4	5	5	5	4	5
213	3	4	4	4	4	4	5	4	5
214	4	4	4	3	4	5	5	4	4
215	3	3	3	4	3	4	4	4	4
216	4	4	4	3	4	4	4	5	4
217	4	5	5	4	5	5	5	4	3
218	4	3	4	4	4	4	4	5	4
219	3	4	5	5	4	5	5	3	3
220	4	4	5	5	5	4	4	3	4
221	3	4	4	4	3	5	4	5	5
222	4	5	3	4	5	3	4	4	4
223	3	4	4	4	4	4	5	4	3
224	4	4	4	3	4	4	4	3	4

NO	BUDAYA ORGANISASI								
	Keterlibatan		Konsistensi		Adaptabilitas			Misi	
	X1.1	X1.2	X1.3	X1.4	X1.5	X1.6	X1.7	X1.8	X1.9
225	4	5	4	4	4	4	5	4	4
226	4	4	4	3	3	4	3	4	3
227	5	4	3	3	4	3	3	4	3
228	4	4	4	5	4	4	4	4	4
229	4	5	4	4	5	4	5	3	3
230	3	4	4	3	4	4	3	4	4
231	4	4	4	4	4	4	5	3	4
232	3	3	3	4	3	3	4	4	4
233	4	4	5	3	4	4	5	5	4
234	3	4	4	3	4	4	3	4	4
235	4	5	4	4	4	4	5	3	3
236	4	3	4	3	4	3	4	4	4
237	3	4	4	4	3	4	5	3	4
238	3	3	3	4	4	3	4	5	4
239	4	4	3	4	3	4	4	4	3
240	5	4	5	5	4	5	5	4	4
241	4	5	5	4	5	3	4	3	3
242	3	4	4	4	4	5	5	3	3
243	4	4	5	3	3	4	4	4	4
244	4	3	4	4	4	5	5	3	4
245	3	4	5	4	3	3	4	4	4
246	3	4	4	4	5	5	5	5	4
247	4	4	5	4	4	4	5	4	4
248	3	4	5	3	4	5	5	3	3
249	4	3	5	4	3	4	4	4	4
250	4	4	4	3	4	4	4	3	4

NO	GAYA KEPEMIMPINAN TRANSFORMASIONAL										
	Pengaruh Ideal / Behavioral		Pengaruh Ideal / Attributed			Motivasi Inspirasional		Stimulasi Intelektual		Pertimbangan Individual	
	X2.1	X2.2	X2.3	X2.4	X2.5	X2.6	X2.7	X2.8	X2.9	X2.10	X2.11
1	3	3	3	3	3	4	4	2	3	4	3
2	3	4	4	4	4	5	5	4	4	5	5
3	4	4	4	4	4	4	4	4	4	4	4
4	4	4	4	4	4	4	4	4	4	4	4
5	4	4	4	4	4	4	4	4	4	4	4
6	4	5	5	5	5	5	5	5	5	5	5
7	4	4	3	4	3	3	3	3	4	4	4
8	4	4	3	4	3	3	3	3	4	4	4
9	4	4	3	4	3	3	3	3	4	4	4
10	4	4	3	4	3	3	3	3	4	4	4
11	4	4	3	4	3	3	3	3	4	4	4
12	4	4	3	4	3	3	3	3	4	4	4
13	4	4	3	4	3	3	3	3	4	4	4
14	4	4	3	4	3	3	3	3	4	4	4
15	4	4	3	4	3	3	3	3	4	4	4
16	4	4	3	4	3	3	3	3	4	4	4
17	4	4	3	4	3	3	3	3	4	4	4
18	4	4	3	4	3	3	3	3	4	4	4
19	4	4	3	4	3	3	3	3	4	4	4
20	4	4	3	4	3	3	3	3	4	4	4
21	4	4	3	4	3	3	3	3	4	4	4
22	4	5	5	4	3	4	4	3	4	4	3
23	3	5	5	5	5	5	5	5	5	5	5
24	4	4	3	4	3	3	3	3	4	4	4
25	4	4	3	4	3	3	3	3	4	4	4
26	4	4	3	4	3	3	3	3	4	4	4
27	4	4	3	4	3	3	3	3	4	4	4
28	4	4	3	4	3	3	3	3	4	4	4
29	4	4	3	4	3	3	3	3	4	4	4
30	4	4	3	4	3	3	3	3	4	4	4
31	4	4	3	4	3	3	3	3	4	4	4
32	4	4	3	4	3	3	3	3	4	4	4

NO	GAYA KEPEMIMPINAN TRANSFORMASIONAL										
	Pengaruh Ideal / Behavioral		Pengaruh Ideal / Attributed			Motivasi Inspirasional		Stimulasi Intelektual		Pertimbangan Individual	
	X2.1	X2.2	X2.3	X2.4	X2.5	X2.6	X2.7	X2.8	X2.9	X2.10	X2.11
33	3	4	4	3	3	4	3	2	4	3	3
34	4	4	3	4	3	3	3	3	4	4	3
35	4	4	4	5	4	3	4	5	3	3	4
36	1	2	1	1	1	1	1	1	1	1	1
37	3	4	4	3	4	4	4	4	4	4	2
38	4	4	4	4	4	4	4	3	3	3	4
39	4	4	4	3	4	4	4	3	4	4	4
40	2	2	2	2	2	2	2	2	2	1	1
41	3	4	5	4	3	3	4	4	3	2	3
42	1	1	4	2	2	2	2	2	2	1	1
43	4	3	5	4	4	3	3	4	4	3	4
44	4	5	3	3	4	4	4	3	5	3	3
45	3	4	4	4	4	4	4	4	4	3	4
46	4	4	4	4	4	4	4	4	4	4	4
47	4	4	4	4	4	4	4	4	4	4	4
48	1	5	4	2	4	4	4	5	5	4	4
49	3	3	3	3	3	4	4	2	3	4	3
50	4	5	4	4	4	3	3	4	4	4	4
51	4	4	4	4	4	4	4	4	4	4	4
52	3	3	3	4	4	4	4	4	4	4	4
53	4	4	4	3	4	4	4	3	4	3	3
54	2	2	2	2	2	3	3	4	3	4	4
55	2	2	2	2	2	2	2	2	2	2	2
56	2	4	4	4	4	4	4	4	4	4	4
57	2	2	4	2	2	2	2	2	2	2	2
58	4	2	4	2	2	2	2	4	2	2	2
59	4	4	4	4	4	4	4	4	4	4	4
60	3	4	5	4	4	4	5	3	4	4	5
61	3	4	3	3	4	3	3	3	4	4	3
62	4	4	3	4	3	3	3	3	4	4	4
63	4	4	3	4	3	3	3	3	4	4	4
64	3	3	1	1	1	1	1	1	1	1	1

NO	GAYA KEPEMIMPINAN TRANSFORMASIONAL										
	Pengaruh Ideal / Behavioral		Pengaruh Ideal / Attributed			Motivasi Inspirasional		Stimulasi Intelektual		Pertimbangan Individual	
	X2.1	X2.2	X2.3	X2.4	X2.5	X2.6	X2.7	X2.8	X2.9	X2.10	X2.11
65	3	4	4	4	4	3	3	3	4	3	3
66	2	2	2	2	2	4	2	2	2	2	2
67	2	2	2	2	2	2	2	4	2	2	2
68	2	4	4	3	3	4	4	3	3	4	4
69	2	2	2	2	2	2	2	2	2	2	2
70	5	3	4	1	2	2	4	3	5	5	4
71	3	4	3	2	1	2	3	2	3	3	3
72	2	2	2	2	2	2	2	2	2	2	2
73	4	3	4	4	4	4	3	3	3	3	4
74	2	2	2	2	2	2	2	2	2	2	2
75	4	4	3	4	3	3	3	3	4	4	4
76	3	4	4	4	4	4	5	4	4	4	4
77	4	4	3	4	3	3	3	3	4	4	4
78	4	4	3	4	3	3	3	3	4	4	4
79	3	4	3	4	3	3	3	3	4	4	4
80	4	4	3	4	3	3	3	3	4	4	4
81	3	4	3	3	4	3	3	4	3	3	4
82	2	3	2	3	3	2	3	3	2	3	3
83	2	2	3	2	2	2	3	3	3	2	2
84	3	3	2	3	3	2	3	3	2	3	2
85	3	2	2	3	3	2	3	2	3	2	3
86	3	3	3	2	3	3	2	3	2	2	3
87	2	2	2	3	2	3	3	2	3	2	3
88	3	3	3	2	3	2	2	3	3	3	3
89	3	3	2	3	2	2	3	3	3	3	2
90	3	3	4	4	4	3	4	3	4	4	4
91	3	3	3	3	3	2	2	3	3	3	3
92	2	2	2	3	2	3	2	2	3	3	3
93	3	3	2	2	2	2	2	2	3	3	4
94	3	3	3	3	4	3	3	4	3	3	4
95	3	4	3	4	4	3	4	4	4	4	3
96	4	3	4	3	3	4	4	3	3	4	4

NO	GAYA KEPEMIMPINAN TRANSFORMASIONAL										
	Pengaruh Ideal / Behavioral		Pengaruh Ideal / Attributed			Motivasi Inspirasional		Stimulasi Intelektual		Pertimbangan Individual	
	X2.1	X2.2	X2.3	X2.4	X2.5	X2.6	X2.7	X2.8	X2.9	X2.10	X2.11
97	3	3	3	3	3	4	3	3	4	3	4
98	3	3	3	2	3	3	2	2	3	3	3
99	3	3	3	2	2	4	3	2	2	3	2
100	4	3	3	3	4	4	3	4	4	3	4
101	3	3	3	3	3	3	4	3	3	3	3
102	3	3	3	4	3	4	4	3	4	4	3
103	3	4	4	4	3	4	3	4	5	4	4
104	4	3	4	3	4	3	4	3	4	4	4
105	3	3	3	3	3	4	3	3	2	3	3
106	4	4	3	4	4	3	3	4	4	4	3
107	4	4	3	4	3	3	4	3	3	4	3
108	3	3	2	3	3	3	2	2	2	4	3
109	4	3	4	4	5	3	4	4	4	5	5
110	4	4	4	3	4	3	4	4	4	3	3
111	3	5	4	4	4	4	4	3	3	2	3
112	3	5	4	3	4	3	3	2	3	3	3
113	3	4	3	4	4	4	3	3	3	4	3
114	2	3	2	3	4	3	3	2	3	3	3
115	4	3	4	3	4	3	4	4	5	4	5
116	4	3	3	3	3	4	3	4	4	4	4
117	3	3	3	4	4	4	4	3	4	3	4
118	3	3	4	3	3	3	4	4	3	4	3
119	3	3	3	4	4	4	3	4	3	5	4
120	3	3	4	3	3	3	4	4	4	4	3
121	3	3	4	3	4	4	3	3	4	3	3
122	4	4	3	4	4	3	3	3	3	4	3
123	3	3	3	4	4	3	3	4	4	4	4
124	3	3	4	3	3	4	4	3	3	3	4
125	3	3	3	4	4	4	4	3	4	4	4
126	3	4	4	3	3	3	4	4	3	3	4
127	4	4	4	3	4	4	3	4	4	4	3
128	3	4	4	3	4	4	4	4	3	4	3

NO	GAYA KEPEMIMPINAN TRANSFORMASIONAL										
	Pengaruh Ideal / Behavioral		Pengaruh Ideal / Attributed			Motivasi Inspirasional		Stimulasi Intelektual		Pertimbangan Individual	
	X2.1	X2.2	X2.3	X2.4	X2.5	X2.6	X2.7	X2.8	X2.9	X2.10	X2.11
129	4	3	3	4	4	3	3	3	4	3	3
130	3	3	4	3	3	4	3	4	3	3	4
131	4	4	3	4	4	3	4	4	4	4	4
132	4	4	4	4	4	4	4	4	4	4	4
133	4	4	5	4	4	5	4	4	4	5	4
134	4	4	4	3	4	4	3	4	4	4	4
135	4	4	4	4	4	4	4	3	4	4	4
136	4	4	5	4	4	5	4	5	5	5	4
137	4	4	4	4	5	4	4	3	4	5	4
138	4	4	5	4	5	5	4	5	5	5	4
139	4	3	4	3	3	3	4	3	3	3	4
140	4	4	4	5	4	4	4	5	5	5	4
141	4	5	5	4	4	4	4	3	4	3	4
142	3	3	4	4	4	3	4	3	3	3	3
143	4	5	4	4	5	4	5	4	4	4	5
144	3	3	4	4	3	4	4	4	3	3	4
145	3	4	3	4	4	3	3	4	4	3	3
146	4	4	4	3	4	4	3	4	3	4	4
147	4	4	4	4	5	5	4	5	4	5	4
148	3	3	4	4	3	3	3	4	4	4	4
149	3	3	4	4	3	3	3	4	4	4	3
150	3	4	3	3	4	4	4	3	3	4	4
151	4	4	3	4	4	4	4	3	3	4	4
152	3	3	2	3	4	3	4	4	4	4	3
153	4	3	4	4	3	3	4	3	3	3	4
154	4	3	4	3	4	5	4	4	4	4	4
155	3	5	4	4	4	3	4	4	4	4	2
156	3	5	4	3	3	4	4	3	3	2	3
157	4	4	4	3	3	4	4	4	4	4	3
158	4	4	4	3	4	4	3	3	4	4	3
159	4	4	3	4	5	4	3	4	3	4	3
160	4	3	3	3	4	3	3	3	3	3	4

NO	GAYA KEPEMIMPINAN TRANSFORMASIONAL										
	Pengaruh Ideal / Behavioral		Pengaruh Ideal / Atributed			Motivasi Inspirasional		Stimulasi Intelektual		Pertimbangan Individual	
	X2.1	X2.2	X2.3	X2.4	X2.5	X2.6	X2.7	X2.8	X2.9	X2.10	X2.11
161	5	5	5	4	3	4	4	3	3	3	3
162	4	5	4	5	5	4	3	4	3	4	3
163	3	3	3	3	3	4	3	3	2	3	3
164	4	5	5	4	3	4	4	4	3	4	3
165	4	4	3	4	3	3	4	3	3	4	3
166	3	3	4	3	3	3	2	2	2	4	3
167	4	3	4	4	5	3	4	4	4	5	5
168	4	3	4	3	4	3	4	3	4	4	4
169	3	5	4	4	4	4	4	3	3	2	3
170	3	5	4	3	4	3	3	4	3	3	3
171	4	4	4	3	4	3	4	4	4	3	3
172	4	4	4	3	4	3	3	4	3	3	3
173	4	4	3	4	4	3	3	4	4	4	3
174	4	3	3	3	3	4	3	4	4	4	4
175	4	3	3	4	4	4	4	3	4	3	4
176	4	4	3	3	3	4	3	4	4	4	3
177	4	3	4	3	4	3	4	4	5	4	5
178	4	4	4	3	4	4	4	3	3	3	4
179	4	3	3	4	4	4	3	4	3	5	4
180	5	4	3	4	4	4	3	3	3	4	3
181	4	3	4	3	3	3	4	4	3	4	3
182	5	4	3	4	4	3	4	4	4	4	3
183	4	3	4	3	3	3	4	4	4	4	3
184	4	4	4	4	4	5	5	3	4	5	4
185	4	5	5	4	4	5	5	4	4	5	5
186	4	4	3	4	4	4	3	3	4	3	4
187	3	4	5	4	4	5	4	4	3	4	4
188	4	4	4	5	5	5	4	4	4	5	4
189	4	4	4	5	5	4	5	4	4	5	4
190	4	5	4	4	5	4	4	4	4	5	5
191	4	5	4	4	5	4	4	4	4	5	5
192	4	4	4	4	5	4	3	4	4	3	4

NO	GAYA KEPEMIMPINAN TRANSFORMASIONAL										
	Pengaruh Ideal / Behavioral		Pengaruh Ideal / Attributed			Motivasi Inspirasional		Stimulasi Intelektual		Pertimbangan Individual	
	X2.1	X2.2	X2.3	X2.4	X2.5	X2.6	X2.7	X2.8	X2.9	X2.10	X2.11
193	4	4	5	5	4	5	4	4	4	4	4
194	3	5	4	4	5	4	3	4	3	5	5
195	5	5	5	5	5	5	5	5	5	5	5
196	4	4	3	3	3	3	4	4	3	3	4
197	4	4	3	3	3	3	4	4	4	3	5
198	4	4	3	3	3	3	4	4	3	3	4
199	4	4	3	3	3	3	4	4	4	4	5
200	4	4	3	3	3	3	4	4	3	3	3
201	4	4	3	3	3	3	4	4	4	4	3
202	4	4	3	3	3	3	4	4	4	3	4
203	4	4	5	5	5	5	5	5	5	5	5
204	4	4	3	3	4	3	3	3	4	4	4
205	4	4	3	3	4	3	3	3	4	4	4
206	5	4	3	3	4	3	3	3	4	4	4
207	3	4	3	3	4	3	3	3	4	4	4
208	3	4	3	3	4	3	3	3	4	4	4
209	3	4	3	3	4	3	3	3	4	4	4
210	3	4	3	3	4	3	3	3	4	4	4
211	4	4	5	5	4	5	4	3	4	3	3
212	3	3	4	3	3	3	4	3	4	3	3
213	3	3	4	3	3	3	4	3	4	3	3
214	5	3	4	3	3	3	4	3	4	3	3
215	5	3	4	3	3	3	4	3	4	3	3
216	4	3	4	3	3	3	4	3	4	3	3
217	4	3	4	4	3	3	4	3	4	3	3
218	4	3	4	4	3	3	4	3	4	3	3
219	4	5	4	4	5	5	5	5	5	4	5
220	4	3	3	5	4	4	4	3	3	4	3
221	4	3	3	3	4	4	4	3	3	4	3
222	4	3	3	3	4	4	4	3	3	4	3
223	5	3	3	3	4	4	4	3	3	4	3
224	4	3	3	3	4	4	4	3	3	4	3

NO	GAYA KEPEMIMPINAN TRANSFORMASIONAL										
	Pengaruh Ideal / Behavioral		Pengaruh Ideal / Atributed			Motivasi Inspirasional		Stimulasi Intelektual		Pertimbangan Individual	
	X2.1	X2.2	X2.3	X2.4	X2.5	X2.6	X2.7	X2.8	X2.9	X2.10	X2.11
225	4	3	3	3	4	4	4	3	3	4	3
226	4	3	3	3	4	4	4	3	3	4	3
227	3	4	5	5	4	4	4	4	4	4	4
228	5	4	3	4	3	3	3	3	4	4	4
229	4	4	3	4	3	3	3	4	4	4	4
230	4	4	3	4	3	3	3	4	4	4	4
231	3	4	3	4	3	3	3	3	4	4	4
232	4	4	3	4	3	3	3	4	4	3	3
233	4	4	3	4	3	3	3	4	3	3	3
234	4	4	3	4	3	3	3	3	4	3	3
235	4	4	4	4	4	4	4	3	3	3	3
236	3	4	3	4	3	3	3	3	4	3	3
237	4	4	3	4	3	3	3	4	3	3	3
238	3	4	3	4	3	3	3	4	4	3	3
239	4	4	3	4	3	3	3	3	4	4	4
240	4	4	3	4	3	3	3	3	4	3	3
241	4	4	3	4	3	3	3	4	3	4	4
242	4	4	3	4	3	3	3	4	4	5	5
243	5	5	5	5	5	4	3	4	4	3	3
244	4	4	3	3	3	4	3	4	3	3	3
245	4	4	3	3	3	5	5	4	3	3	3
246	4	4	3	3	3	4	3	4	3	3	3
247	4	4	3	3	3	4	3	4	3	3	3
248	4	4	3	3	3	4	3	4	3	3	3
249	4	4	3	3	3	4	3	4	3	3	3
250	4	4	3	3	3	4	3	4	3	4	3

NO	KEPUASAN KERJA											
	Pekerjaan		Atasan		Teman Sekerja		Karier / Promosi		Gaji/Upah		Lingkungan	
	Y1.1	Y1.2	Y1.3	Y1.4	Y1.5	Y1.6	Y1.7	Y1.8	Y1.9	Y1.10	Y1.11	Y1.12
1	4	4	4	3	3	3	3	4	3	3	4	4
2	4	4	5	5	4	4	4	4	3	3	4	4
3	1	4	4	4	4	4	4	4	4	4	4	4
4	4	4	4	4	4	4	3	3	4	4	4	4
5	4	4	4	4	4	4	4	4	4	4	4	4
6	4	4	5	5	5	5	3	3	4	4	4	3
7	4	4	3	4	4	4	2	2	4	4	4	4
8	4	4	3	4	4	4	2	2	4	4	4	4
9	4	4	3	4	4	4	2	2	4	4	4	4
10	4	4	3	4	4	4	2	2	4	4	4	4
11	4	4	3	4	4	4	2	2	4	4	4	4
12	4	4	3	4	4	4	2	2	4	4	4	4
13	4	4	3	4	4	4	2	2	4	4	4	4
14	4	4	3	4	4	4	2	2	4	4	4	4
15	4	4	3	4	4	4	2	2	4	4	4	4
16	4	4	3	4	4	4	2	2	4	4	4	4
17	4	4	3	4	4	4	2	2	4	4	4	4
18	4	4	3	4	4	4	2	2	4	4	4	4
19	4	4	3	4	4	4	2	2	4	4	4	4
20	4	4	3	4	4	4	2	2	4	4	4	4
21	4	4	3	4	4	4	2	2	4	4	4	4
22	3	5	4	4	5	4	4	3	4	2	5	5
23	5	5	5	5	5	3	3	3	5	5	5	5
24	4	4	3	4	4	4	2	2	4	4	4	4
25	4	4	3	4	4	4	2	2	4	4	4	4
26	4	4	3	4	4	4	2	2	4	4	4	4
27	4	4	3	4	4	4	2	2	4	4	4	4
28	4	4	3	4	4	4	2	2	4	4	4	4
29	4	4	3	4	4	4	2	2	4	4	4	4
30	4	4	3	4	4	4	2	2	4	4	4	4
31	4	4	3	4	4	4	2	2	4	4	4	4
32	4	4	3	4	4	4	2	2	4	4	4	4

NO	KEPUASAN KERJA											
	Pekerjaan		Atasan		Teman Sekerja		Karier / Promosi		Gaji/Upah		Lingkungan	
	Y1.1	Y1.2	Y1.3	Y1.4	Y1.5	Y1.6	Y1.7	Y1.8	Y1.9	Y1.10	Y1.11	Y1.12
33	4	4	3	3	4	2	2	2	2	2	2	2
34	5	4	3	4	5	4	3	4	2	4	3	4
35	4	4	3	3	5	5	4	4	3	3	3	5
36	2	1	1	1	4	4	1	1	4	4	4	4
37	4	4	3	4	3	3	3	3	3	2	2	4
38	3	4	3	3	2	2	3	3	3	3	4	4
39	3	3	3	3	3	3	3	3	2	2	2	2
40	2	2	2	2	2	2	2	2	2	2	2	2
41	2	3	4	4	3	4	3	4	3	3	4	4
42	2	4	1	2	4	2	1	1	1	1	2	4
43	4	5	2	3	4	4	4	4	3	4	3	4
44	4	4	3	3	3	4	3	3	4	4	4	4
45	4	4	4	4	3	3	2	2	3	3	2	4
46	3	4	4	4	3	2	2	3	1	1	2	4
47	3	4	4	4	3	2	2	3	1	1	2	4
48	5	5	4	4	3	3	3	3	3	3	3	3
49	4	4	4	3	3	3	3	3	3	3	4	4
50	4	4	4	4	3	3	3	3	4	4	3	3
51	4	4	4	4	4	2	2	2	2	2	2	4
52	4	4	4	3	4	4	4	4	4	4	4	4
53	4	4	3	3	2	2	3	3	2	2	2	4
54	4	4	2	1	5	4	1	1	4	3	3	4
55	4	4	2	2	2	2	2	2	2	2	4	4
56	4	4	4	4	4	4	2	2	2	2	4	4
57	4	4	2	2	2	2	2	2	2	2	2	4
58	2	4	2	2	2	2	2	2	2	2	4	4
59	3	4	3	4	3	4	4	4	4	4	3	3
60	5	4	5	5	4	4	5	5	4	2	5	5
61	3	3	3	4	4	4	3	3	3	4	3	4
62	4	4	3	4	4	4	2	2	4	4	4	4
63	4	4	3	4	4	4	2	2	4	4	4	4
64	4	3	1	1	3	3	1	1	1	1	3	3

NO	KEPUASAN KERJA											
	Pekerjaan		Atasan		Teman Sekerja		Karier / Promosi		Gaji/Upah		Lingkungan	
	Y1.1	Y1.2	Y1.3	Y1.4	Y1.5	Y1.6	Y1.7	Y1.8	Y1.9	Y1.10	Y1.11	Y1.12
65	4	4	3	3	4	4	3	3	3	3	2	3
66	4	4	2	2	2	2	2	2	2	2	4	4
67	4	4	2	2	2	2	2	2	2	2	4	4
68	4	4	3	3	4	4	2	3	3	3	2	1
69	4	4	2	2	2	2	2	2	2	2	4	4
70	5	3	3	5	4	4	3	4	4	3	4	5
71	4	3	2	1	2	2	1	1	1	1	4	4
72	5	5	2	2	2	2	2	2	2	2	2	4
73	4	4	3	3	4	4	4	4	3	4	4	3
74	5	5	2	2	2	2	2	2	2	2	4	4
75	4	4	3	4	4	4	2	2	4	4	4	4
76	5	5	4	4	2	2	1	1	4	5	2	3
77	4	4	3	4	4	4	2	2	4	4	4	4
78	4	4	3	4	4	4	2	2	4	4	4	4
79	4	4	3	4	4	4	2	2	4	4	4	4
80	4	4	3	4	4	4	2	2	4	4	4	4
81	4	4	3	4	2	3	3	2	3	3	4	4
82	4	4	3	3	3	3	3	3	3	2	4	3
83	3	3	2	2	2	2	2	2	2	2	3	3
84	3	3	2	2	3	3	2	2	2	3	3	3
85	3	3	2	3	3	3	3	3	2	3	3	4
86	3	3	2	3	2	3	2	2	2	2	3	3
87	3	3	2	2	2	2	2	3	3	2	3	3
88	3	3	2	2	2	2	2	2	2	2	3	3
89	3	3	3	2	3	2	2	3	2	3	3	3
90	4	4	3	3	3	3	3	3	3	3	4	4
91	3	3	2	2	2	3	2	2	2	2	3	3
92	3	3	2	2	3	3	2	2	2	2	3	3
93	4	4	3	3	3	3	2	3	2	3	3	3
94	3	4	3	3	4	4	3	3	3	3	4	5
95	4	3	3	3	4	4	3	3	2	3	4	4
96	4	4	4	3	4	4	3	3	3	3	4	4

NO	KEPUASAN KERJA											
	Pekerjaan		Atasan		Teman Sekerja		Karier / Promosi		Gaji/Upah		Lingkungan	
	Y1.1	Y1.2	Y1.3	Y1.4	Y1.5	Y1.6	Y1.7	Y1.8	Y1.9	Y1.10	Y1.11	Y1.12
97	4	4	3	3	4	4	3	3	3	3	4	4
98	3	3	2	2	3	3	2	2	2	3	4	4
99	3	3	2	2	4	4	2	3	3	2	4	4
100	4	4	4	3	4	5	3	4	3	3	5	4
101	3	4	3	3	3	4	3	2	2	2	4	4
102	4	4	3	3	4	5	3	3	3	3	4	5
103	4	4	3	4	5	5	4	4	4	3	5	5
104	4	4	3	3	4	5	3	3	3	3	5	4
105	3	4	3	3	4	4	3	3	2	3	5	4
106	4	4	3	4	5	4	3	4	3	3	5	4
107	3	4	3	3	5	5	3	3	2	3	5	4
108	3	3	3	2	5	5	3	4	3	3	5	5
109	3	4	3	4	4	5	3	4	4	3	5	5
110	4	4	3	4	5	4	3	4	4	3	5	4
111	4	3	4	4	5	5	3	2	3	3	5	5
112	3	4	3	4	5	4	3	4	4	4	5	5
113	3	4	3	3	4	5	3	4	3	3	5	5
114	3	4	3	3	4	4	3	3	3	2	5	4
115	4	4	4	3	5	5	4	3	4	3	5	5
116	4	3	4	4	5	4	3	3	4	3	5	5
117	3	4	3	3	5	4	3	3	2	3	5	5
118	4	5	3	4	5	5	3	3	2	3	5	5
119	4	4	3	3	5	5	3	4	3	3	5	5
120	4	3	3	4	5	5	3	2	2	2	4	4
121	3	4	3	3	5	4	3	4	3	3	5	5
122	3	4	3	4	4	5	3	4	3	2	4	4
123	4	4	3	4	5	5	4	4	3	3	5	5
124	4	4	3	3	5	5	4	4	3	3	5	5
125	4	4	4	3	5	5	4	4	3	3	5	5
126	4	4	3	3	5	4	4	3	3	3	4	4
127	4	4	3	4	5	5	4	4	3	3	5	5
128	4	4	3	4	4	4	3	4	3	3	5	5

NO	KEPUASAN KERJA											
	Pekerjaan		Atasan		Teman Sekerja		Karier / Promosi		Gaji/Upah		Lingkungan	
	Y1.1	Y1.2	Y1.3	Y1.4	Y1.5	Y1.6	Y1.7	Y1.8	Y1.9	Y1.10	Y1.11	Y1.12
129	4	4	3	3	5	5	3	4	4	3	4	5
130	5	5	4	4	5	4	4	4	3	3	5	5
131	5	5	3	4	5	5	4	4	3	4	5	4
132	5	5	4	4	5	5	4	4	4	4	5	5
133	4	4	4	3	5	4	4	3	3	3	5	4
134	4	4	4	4	5	5	4	4	4	3	5	5
135	4	4	4	4	5	5	4	4	3	3	5	5
136	4	4	4	4	4	5	4	4	3	3	5	5
137	4	4	3	4	5	5	4	4	3	3	5	4
138	5	5	4	4	5	5	4	4	4	4	5	5
139	5	5	4	4	5	5	4	4	3	4	5	5
140	5	4	4	4	5	5	4	4	3	3	5	4
141	5	5	4	3	4	4	4	4	4	4	5	4
142	4	4	3	4	5	5	4	4	5	5	5	5
143	5	4	4	4	5	5	4	4	3	3	5	5
144	4	4	4	4	5	5	4	4	4	4	4	4
145	4	4	4	4	5	5	4	3	3	4	5	5
146	5	4	4	4	5	5	4	3	3	3	5	5
147	4	4	4	4	4	4	4	3	4	4	5	5
148	4	4	4	4	5	5	4	5	3	3	5	5
149	4	4	3	4	4	4	4	4	3	4	4	5
150	5	4	4	4	5	5	4	3	3	3	5	5
151	5	4	4	4	4	4	4	4	3	3	4	5
152	4	4	4	5	3	4	4	3	4	3	4	4
153	5	5	4	4	4	4	5	4	4	4	4	3
154	5	5	4	3	4	4	4	4	4	3	4	4
155	4	4	3	4	4	4	3	4	4	3	4	3
156	5	5	3	4	5	3	4	5	3	3	5	4
157	4	4	4	4	4	3	4	3	3	4	4	4
158	5	5	4	4	4	4	4	3	3	3	3	4
159	4	5	4	4	5	4	4	4	2	3	4	5
160	5	4	5	3	5	4	4	4	4	3	4	3

NO	KEPUASAN KERJA											
	Pekerjaan		Atasan		Teman Sekerja		Karier / Promosi		Gaji/Upah		Lingkungan	
	Y1.1	Y1.2	Y1.3	Y1.4	Y1.5	Y1.6	Y1.7	Y1.8	Y1.9	Y1.10	Y1.11	Y1.12
161	5	4	4	4	4	5	3	4	4	3	4	3
162	4	4	3	3	4	4	3	4	3	5	4	4
163	3	4	3	3	4	4	3	3	2	3	4	4
164	4	3	4	3	5	4	3	3	4	4	3	4
165	3	4	3	3	5	5	3	3	2	3	5	4
166	3	3	3	2	5	5	3	4	3	3	5	5
167	3	4	3	4	4	5	3	4	4	3	5	5
168	4	4	3	3	4	5	3	3	3	3	5	4
169	4	3	4	4	5	5	3	4	3	3	5	5
170	3	4	3	4	5	4	3	4	4	4	5	5
171	4	4	3	4	5	4	3	4	4	3	5	4
172	4	4	3	3	4	4	3	4	3	2	5	4
173	4	4	3	4	5	4	3	4	3	3	5	4
174	4	3	4	4	5	4	3	2	4	3	5	5
175	3	4	3	3	5	4	3	3	2	3	5	5
176	4	4	4	4	5	5	3	3	4	3	5	4
177	4	4	4	3	5	5	4	3	4	3	5	5
178	4	4	3	3	5	3	4	3	4	3	4	5
179	4	4	3	3	5	5	3	4	3	3	5	5
180	4	4	3	3	4	5	3	4	3	3	5	5
181	4	5	3	4	5	5	3	3	2	3	5	5
182	4	3	3	4	4	4	4	3	4	3	4	4
183	4	3	3	4	5	5	3	4	2	2	4	4
184	4	3	5	5	3	4	4	4	3	4	4	3
185	4	4	4	4	5	4	4	3	3	4	5	4
186	5	4	5	5	4	5	4	4	3	3	4	5
187	4	5	4	4	4	4	4	4	3	3	4	4
188	5	4	5	5	4	5	4	4	3	3	4	5
189	4	4	4	4	4	4	4	4	4	3	4	4
190	4	5	5	4	5	5	4	5	4	3	4	4
191	5	4	5	5	4	4	4	4	3	3	4	4
192	4	5	4	4	4	4	4	4	3	3	4	4

NO	KEPUASAN KERJA											
	Pekerjaan		Atasan		Teman Sekerja		Karier / Promosi		Gaji/Upah		Lingkungan	
	Y1.1	Y1.2	Y1.3	Y1.4	Y1.5	Y1.6	Y1.7	Y1.8	Y1.9	Y1.10	Y1.11	Y1.12
193	5	5	4	4	4	5	4	4	3	3	4	5
194	4	5	5	5	5	5	4	4	3	3	5	5
195	5	4	5	5	5	4	4	4	3	3	5	4
196	5	4	5	5	4	4	4	4	4	3	4	4
197	4	4	4	4	4	4	4	4	3	3	4	4
198	5	4	5	4	5	4	4	4	3	3	5	5
199	4	4	4	5	4	4	4	4	4	3	4	4
200	4	5	5	4	5	5	4	4	4	3	5	5
201	4	4	4	4	4	4	4	4	3	3	4	5
202	5	4	4	5	4	5	4	4	3	3	5	5
203	4	4	5	4	5	4	4	4	4	3	4	5
204	4	5	4	5	4	4	4	4	4	3	4	4
205	5	4	5	5	4	4	4	4	4	3	5	5
206	4	4	4	5	5	5	4	4	3	3	5	5
207	5	5	5	4	5	5	4	5	3	3	4	5
208	4	4	5	4	5	4	4	4	4	3	4	4
209	4	5	4	4	4	4	4	4	4	3	4	4
210	5	4	4	4	4	4	4	5	3	3	4	5
211	4	4	5	4	4	4	4	4	3	3	4	4
212	5	4	4	4	5	4	4	4	3	3	4	5
213	5	4	4	4	4	4	4	4	3	3	4	4
214	4	4	5	5	5	5	4	4	3	3	5	5
215	4	4	4	5	4	4	4	4	3	3	4	4
216	4	4	5	4	4	4	4	4	3	3	4	4
217	4	4	5	4	4	4	4	5	3	3	4	5
218	5	4	5	4	5	5	5	5	3	3	5	5
219	5	4	4	4	5	4	5	4	3	3	5	4
220	4	4	4	4	4	4	4	4	3	3	4	4
221	4	4	4	4	4	4	4	4	3	3	4	4
222	4	4	3	3	2	5	4	3	3	3	5	5
223	4	3	5	3	3	3	5	5	2	3	4	4
224	5	5	3	4	3	5	4	3	3	3	5	5

NO	KEPUASAN KERJA											
	Pekerjaan		Atasan		Teman Sekerja		Karier / Promosi		Gaji/Upah		Lingkungan	
	Y1.1	Y1.2	Y1.3	Y1.4	Y1.5	Y1.6	Y1.7	Y1.8	Y1.9	Y1.10	Y1.11	Y1.12
225	3	4	4	4	3	4	4	4	3	3	4	5
226	5	4	4	4	3	4	3	4	3	3	5	5
227	4	4	4	5	2	4	4	4	3	2	4	5
228	5	5	4	4	2	5	4	4	3	2	4	4
229	3	4	3	3	4	4	4	3	4	4	5	5
230	3	3	3	4	3	3	3	3	3	3	5	5
231	3	4	3	4	3	4	4	3	3	3	4	5
232	4	4	3	4	4	4	4	3	4	4	4	4
233	4	3	3	4	3	3	4	3	3	3	4	4
234	3	4	3	3	4	3	3	2	3	4	4	5
235	4	4	3	4	4	3	3	3	3	4	4	4
236	4	5	3	3	2	4	4	3	3	3	4	5
237	4	3	5	3	3	4	5	3	4	4	4	4
238	5	5	3	4	3	4	3	3	3	3	5	5
239	3	4	4	4	3	5	5	5	3	3	4	4
240	5	4	4	4	3	4	5	5	3	4	4	4
241	4	4	4	5	2	3	4	5	3	4	4	5
242	5	5	4	4	2	4	4	5	4	3	5	5
243	3	4	3	3	4	4	5	4	4	3	5	4
244	3	3	3	4	3	4	4	5	3	3	4	4
245	3	4	3	4	3	4	5	4	3	4	4	4
246	4	4	3	4	4	3	4	5	2	3	5	5
247	4	3	3	4	3	4	4	3	4	3	4	4
248	3	4	3	3	4	4	5	5	3	4	5	5
249	4	4	3	4	4	3	4	4	4	4	4	5
250	4	4	4	4	3	4	5	3	3	3	5	5

NO	KINERJA KARYAWAN													
	Kualitas kerja		Efisiensi		Kemampuan Karyawan		Ketepatan waktu		Pengetahuan Karyawan		Kreatifitas		Mengikuti Prosedur	
	Y.2.1	Y.2.1	Y.2.3	Y.2.4	Y.2.5	Y.2.6	Y.2.7	Y.2.8	Y.2.9	Y.2.10	Y.2.11	Y.2.12	Y.2.13	Y.2.14
1	3	3	3	3	3	3	3	4	4	3	3	3	3	3
2	4	3	4	4	4	4	4	4	4	4	4	3	4	4
3	4	4	2	4	5	4	5	4	5	4	4	4	4	4
4	4	4	4	4	4	4	3	3	4	4	3	3	4	4
5	4	3	4	4	4	4	4	3	4	4	4	3	4	4
6	5	5	4	4	5	3	5	3	4	3	4	4	5	4
7	4	3	4	4	4	4	4	4	4	3	3	3	3	3
8	4	3	4	4	4	4	4	4	4	3	3	3	3	3
9	4	3	4	4	4	4	4	4	4	3	3	3	3	3
10	4	3	4	4	4	4	4	4	4	3	3	3	3	3
11	4	3	4	4	4	4	4	4	4	3	3	3	3	3
12	4	3	4	4	4	4	4	4	4	3	3	3	3	3
13	4	3	4	4	4	4	4	4	4	3	3	3	3	3
14	4	3	4	4	4	4	4	4	4	3	3	3	3	3
15	4	3	4	4	4	4	4	4	4	3	3	3	3	3
16	4	3	4	4	4	4	4	4	4	3	3	3	3	3
17	4	3	4	4	4	4	4	4	4	3	3	3	3	3
18	4	3	4	4	4	4	4	4	4	3	3	3	3	3
19	4	3	4	4	4	4	4	4	4	3	3	3	4	5
20	4	3	4	4	4	4	4	4	4	3	3	3	3	3
21	4	3	4	4	4	4	4	4	4	3	3	3	3	3
22	4	4	4	4	4	4	4	4	4	5	2	4	4	4
23	3	3	3	1	3	5	3	3	3	3	3	3	3	3
24	4	3	4	4	4	4	4	4	4	3	3	3	3	3
25	4	3	4	4	4	4	4	4	4	3	3	3	3	3
26	4	3	4	4	4	4	4	4	4	3	3	3	3	3
27	4	3	4	4	4	4	4	4	4	3	3	3	3	3
28	4	3	4	4	4	4	4	4	4	3	3	3	3	3
29	4	3	4	4	4	4	4	4	4	3	3	3	3	3
30	4	3	4	4	4	4	4	4	4	3	3	3	3	3
31	4	3	4	4	4	4	4	4	4	3	3	3	3	3
32	4	3	4	4	4	4	4	4	4	3	3	3	3	3

NO	KINERJA KARYAWAN													
	Kualitas kerja		Efisiensi		Kemampuan Karyawan		Ketepatan waktu		Pengetahuan Karyawan		Kreatifitas		Mengikuti Prosedur	
	Y.2.1	Y.2.1	Y.2.3	Y.2.4	Y.2.5	Y.2.6	Y.2.7	Y.2.8	Y.2.9	Y.2.10	Y.2.11	Y.2.12	Y.2.13	Y.2.14
33	3	3	3	3	4	4	4	3	4	3	4	3	3	3
34	4	3	4	3	4	2	5	4	4	4	4	3	5	4
35	4	3	4	4	3	3	4	4	4	3	3	3	4	4
36	4	4	5	4	5	4	4	5	5	1	4	5	5	4
37	4	3	4	3	4	3	3	2	4	3	3	4	4	4
38	4	4	4	4	4	3	3	4	4	4	3	3	4	4
39	3	4	4	4	4	3	3	2	3	3	4	3	3	3
40	2	3	2	2	3	2	3	4	4	4	4	4	4	4
41	4	4	3	3	3	3	3	4	4	4	3	3	3	3
42	4	3	4	2	5	2	4	3	5	2	2	2	4	4
43	4	4	3	3	4	4	3	3	3	4	3	3	4	4
44	3	4	3	3	3	4	4	3	4	3	4	4	5	4
45	2	3	4	4	4	3	4	2	3	3	3	3	4	4
46	4	3	4	4	4	4	4	2	4	4	4	3	4	4
47	4	3	4	4	4	4	4	2	4	4	4	3	4	4
48	4	3	4	4	4	4	4	4	4	4	3	4	4	3
49	3	3	3	3	3	3	3	4	4	3	3	3	3	3
50	3	3	4	4	3	3	4	4	3	4	4	4	3	3
51	4	4	4	4	4	2	4	2	4	2	4	3	4	4
52	4	3	4	4	4	4	4	3	4	4	4	4	4	3
53	4	4	4	4	4	4	4	4	4	2	4	4	4	4
54	4	3	4	4	4	4	4	3	4	4	4	3	4	3
55	4	4	4	4	4	4	4	4	4	4	4	4	4	4
56	4	4	4	4	4	4	4	4	4	4	4	4	4	4
57	4	4	4	4	4	4	4	2	4	4	4	4	4	4
58	4	4	4	4	4	4	4	4	4	2	4	4	4	4
59	4	4	1	1	3	1	4	4	3	3	3	3	3	3
60	5	4	4	4	5	4	4	5	4	5	5	5	5	4
61	3	4	3	4	3	4	4	3	4	4	3	4	3	4
62	4	3	4	4	4	4	4	4	4	3	3	3	3	3
63	4	3	4	4	4	4	4	4	4	3	3	3	3	3
64	3	3	3	5	5	3	4	4	5	3	4	4	3	3

NO	KINERJA KARYAWAN													
	Kualitas kerja		Efisiensi		Kemampuan Karyawan		Ketepatan waktu		Pengetahuan Karyawan		Kreatifitas		Mengikuti Prosedur	
	Y.2.1	Y.2.1	Y.2.3	Y.2.4	Y.2.5	Y.2.6	Y.2.7	Y.2.8	Y.2.9	Y.2.10	Y.2.1	Y.2.1	Y.2.1	Y.2.1
65	4	3	3	3	4	4	4	4	4	4	4	4	4	4
66	4	4	4	4	4	4	4	4	4	4	4	4	4	4
67	4	4	4	4	4	4	4	4	4	4	4	4	4	4
68	4	4	4	4	4	4	3	3	4	2	3	3	4	5
69	4	4	4	4	4	4	4	4	4	4	4	4	4	4
70	1	3	4	2	3	4	5	5	4	5	4	3	5	4
71	5	4	4	4	5	3	4	2	5	5	3	3	3	3
72	4	4	4	4	4	2	4	2	4	4	4	4	4	4
73	4	4	4	4	3	3	4	4	4	4	3	3	4	4
74	5	5	5	5	5	2	5	5	5	5	5	5	5	5
75	4	3	4	4	4	4	4	4	4	3	3	3	3	3
76	5	5	4	5	5	2	5	5	5	5	5	5	5	5
77	4	3	4	4	4	4	4	4	4	3	3	3	3	3
78	4	3	4	4	4	4	4	4	4	3	3	3	3	3
79	4	3	4	4	4	4	4	4	4	3	3	3	3	3
80	4	3	4	4	4	4	4	4	4	3	3	3	3	3
81	4	4	4	4	5	5	4	4	4	4	3	3	3	3
82	4	3	3	4	4	4	4	4	4	4	3	3	3	3
83	4	3	3	4	4	4	4	4	4	3	3	4	4	4
84	4	5	5	4	4	4	5	5	4	4	4	4	4	4
85	5	4	4	4	4	4	5	4	3	3	4	3	4	4
86	3	4	4	3	4	3	4	4	3	3	3	3	4	4
87	3	4	4	3	3	3	4	3	4	3	3	3	4	4
88	3	3	4	3	3	3	4	4	3	4	3	3	4	4
89	3	3	3	3	3	4	4	4	3	3	3	3	4	4
90	4	5	5	4	4	4	5	5	4	3	4	4	5	5
91	4	3	5	4	4	4	4	5	4	4	3	4	5	5
92	4	3	3	4	4	4	4	4	3	4	3	3	5	5
93	4	3	3	3	4	4	5	5	4	4	4	3	5	5
94	5	5	5	3	4	4	4	5	4	4	3	4	5	5
95	5	4	5	5	4	4	5	5	4	4	4	4	5	5
96	4	4	4	4	4	5	5	5	5	4	5	5	5	4

NO	KINERJA KARYAWAN													
	Kualitas kerja		Efisiensi		Kemampuan Karyawan		Ketepatan waktu		Pengetahuan Karyawan		Kreatifitas		Mengikuti Prosedur	
	Y.2.1	Y.2.1	Y.2.3	Y.2.4	Y.2.5	Y.2.6	Y.2.7	Y.2.8	Y.2.9	Y.2.10	Y.2.11	Y.2.12	Y.2.13	Y.2.14
97	3	4	4	4	4	4	5	5	4	4	4	4	5	5
98	4	3	4	4	3	4	4	4	4	3	4	3	4	5
99	4	4	4	5	4	4	3	3	4	4	3	3	4	4
100	4	5	4	5	4	4	5	5	4	4	4	4	5	5
101	4	3	3	4	4	3	4	5	4	4	3	3	4	4
102	5	5	5	4	4	4	5	5	5	4	5	5	5	4
103	5	4	4	5	4	5	4	4	4	4	4	5	4	5
104	4	5	5	4	5	5	3	4	3	4	4	3	4	4
105	3	4	4	3	4	3	4	4	3	4	4	4	4	3
106	3	4	5	4	5	4	4	5	4	4	4	5	4	5
107	4	5	4	4	5	4	5	5	4	4	4	4	4	4
108	5	4	4	4	4	4	4	4	5	4	4	5	5	4
109	5	4	5	5	4	3	5	4	4	3	4	5	5	5
110	5	4	3	4	3	3	4	4	5	4	3	4	4	4
111	4	4	3	4	3	4	4	4	4	3	3	4	4	4
112	5	4	4	4	3	5	4	5	4	4	3	4	5	4
113	3	4	4	4	4	3	5	4	4	4	5	4	5	5
114	3	3	3	4	3	4	4	3	3	3	4	3	4	4
115	4	5	5	4	4	4	5	4	4	3	4	4	4	5
116	3	4	4	3	4	4	5	5	4	3	3	4	4	5
117	4	3	4	4	4	3	4	4	4	4	3	4	4	3
118	4	4	3	4	4	3	4	4	3	4	4	4	4	4
119	4	4	3	4	4	4	4	4	3	4	4	4	4	4
120	4	4	4	3	3	4	4	5	4	4	4	3	5	4
121	3	4	4	4	4	3	4	4	4	3	4	3	4	4
122	3	3	4	4	3	4	4	4	3	4	4	4	4	4
123	4	4	4	5	4	4	5	5	4	4	4	4	5	5
124	4	4	4	4	4	4	4	4	4	4	4	4	5	4
125	5	5	4	5	5	4	5	5	4	5	4	4	5	5
126	4	3	3	4	4	4	4	4	4	4	4	4	4	5
127	4	4	4	5	4	4	5	4	4	5	4	5	4	4
128	4	4	4	5	4	4	4	5	4	4	4	4	4	5

NO	KINERJA KARYAWAN													
	Kualitas kerja		Efisiensi		Kemampuan Karyawan		Ketepatan waktu		Pengetahuan Karyawan		Kreatifitas		Mengikuti Prosedur	
	Y.2.1	Y.2.1	Y.2.3	Y.2.4	Y.2.5	Y.2.6	Y.2.7	Y.2.8	Y.2.9	Y.2.10	Y.2.11	Y.2.12	Y.2.13	Y.2.14
129	3	4	4	4	3	4	4	4	4	4	4	4	4	5
130	5	5	4	5	4	5	5	5	5	4	5	5	5	5
131	4	4	5	4	4	5	4	5	4	5	5	5	5	5
132	4	5	5	5	5	5	5	5	5	5	5	4	5	5
133	5	5	5	5	5	4	5	5	5	4	4	4	5	5
134	4	5	4	5	4	4	5	5	5	5	4	5	5	5
135	4	5	4	5	5	5	5	5	5	5	5	5	5	5
136	4	4	5	5	5	4	5	5	4	4	4	4	5	5
137	4	5	5	5	5	4	4	5	4	4	4	5	5	4
138	4	4	4	4	5	4	5	5	4	4	4	5	5	4
139	5	4	4	5	4	5	4	4	4	4	4	4	4	4
140	4	5	5	4	5	4	5	5	5	4	4	5	5	4
141	4	4	4	5	4	4	4	4	4	4	4	4	5	4
142	5	4	5	4	4	5	5	4	5	5	5	5	5	5
143	4	4	5	4	5	4	5	5	4	4	4	4	5	4
144	4	4	4	5	4	5	4	4	4	4	4	4	4	4
145	4	4	4	4	5	5	4	4	4	4	4	5	5	4
146	4	5	5	4	4	5	5	5	5	5	5	5	5	5
147	4	5	5	5	5	4	5	5	5	4	5	4	5	5
148	4	5	4	4	5	4	5	5	4	4	4	4	4	4
149	5	4	4	4	4	4	4	4	4	4	4	4	4	4
150	4	4	4	5	4	4	4	4	4	4	4	4	5	4
151	5	4	3	4	3	4	3	4	4	5	4	4	5	5
152	4	3	4	4	4	3	4	4	4	4	4	4	4	5
153	5	5	4	5	4	4	4	5	4	5	5	5	5	5
154	4	4	5	5	5	4	5	5	4	4	4	4	4	5
155	4	4	4	4	4	4	4	5	4	4	4	4	4	4
156	5	5	5	4	5	5	5	5	5	4	4	4	5	5
157	4	5	5	5	4	4	4	5	4	5	5	5	5	5
158	5	4	4	4	4	4	4	4	4	5	4	5	4	5
159	5	4	4	4	4	4	5	5	4	4	4	4	4	4
160	5	4	5	5	5	5	5	5	5	4	3	3	4	4

NO	KINERJA KARYAWAN													
	Kualitas kerja		Efisiensi		Kemampuan Karyawan		Ketepatan waktu		Pengetahuan Karyawan		Kreatifitas		Mengikuti Prosedur	
	Y.2.1	Y.2.1	Y.2.3	Y.2.4	Y.2.5	Y.2.6	Y.2.7	Y.2.8	Y.2.9	Y.2.10	Y.2.11	Y.2.12	Y.2.13	Y.2.14
161	4	4	5	5	5	4	4	5	5	3	4	4	3	4
162	4	4	5	5	4	4	4	5	4	3	4	3	4	4
163	3	4	4	3	4	3	4	4	3	4	4	4	4	3
164	5	4	3	4	3	4	3	4	4	4	4	4	4	4
165	4	3	4	4	4	3	4	4	4	4	4	4	4	4
166	5	4	4	4	4	4	4	4	5	4	4	5	5	4
167	5	4	5	5	4	3	5	4	4	3	4	5	5	5
168	4	5	5	4	5	5	3	4	3	4	4	3	4	4
169	4	4	3	4	3	4	4	4	4	3	3	4	4	4
170	5	4	4	4	3	5	4	5	4	4	3	4	5	4
171	5	4	3	4	3	3	4	4	5	4	3	4	4	4
172	3	3	3	4	3	4	4	3	3	3	4	3	4	4
173	3	4	5	4	5	4	4	5	4	4	4	5	4	5
174	3	4	4	3	4	4	5	5	4	3	3	4	4	5
175	4	4	4	4	4	3	4	4	4	4	3	4	4	3
176	4	5	5	4	3	3	5	4	4	4	4	4	3	4
177	4	5	5	4	4	4	5	4	5	5	4	3	3	5
178	4	4	4	4	4	4	4	4	4	4	5	4	4	5
179	5	4	5	5	4	3	5	4	3	4	4	4	4	4
180	3	4	4	4	4	3	5	4	4	4	5	4	5	5
181	4	4	4	4	4	3	4	4	3	4	4	4	4	4
182	4	5	5	4	3	3	4	4	4	5	5	4	5	4
183	4	4	4	3	3	4	4	5	4	4	4	3	5	4
184	4	4	4	4	4	4	5	5	4	4	4	4	5	4
185	5	5	4	4	4	4	4	4	4	4	4	4	5	5
186	4	4	5	4	4	4	5	4	5	4	5	4	5	4
187	4	4	5	5	4	4	5	5	4	4	5	5	5	4
188	5	4	4	4	4	4	4	4	4	4	4	4	5	4
189	4	4	5	5	5	4	5	5	4	4	4	4	5	4
190	4	4	4	4	4	4	4	5	4	4	4	4	5	4
191	5	5	5	4	5	5	5	5	5	4	4	4	5	4
192	4	5	5	5	4	4	4	5	4	4	4	4	5	4

NO	KINERJA KARYAWAN													
	Kualitas kerja		Efisiensi		Kemampuan Karyawan		Ketepatan waktu		Pengetahuan Karyawan		Kreatifitas		Mengikuti Prosedur	
	Y.2.1	Y.2.1	Y.2.3	Y.2.4	Y.2.5	Y.2.6	Y.2.7	Y.2.8	Y.2.9	Y.2.10	Y.2.11	Y.2.12	Y.2.13	Y.2.14
193	5	4	4	4	4	4	4	4	4	4	4	4	5	4
194	5	4	4	4	4	4	5	5	4	4	4	4	5	4
195	5	4	5	5	5	5	5	5	5	4	4	4	4	4
196	4	4	5	5	5	4	4	5	5	4	4	4	5	4
197	4	4	5	5	4	4	4	4	4	4	4	4	4	4
198	4	4	4	4	4	4	4	4	4	4	4	4	4	4
199	4	4	4	4	5	4	5	5	4	4	4	5	5	4
200	4	4	5	4	4	5	4	4	4	4	4	4	4	4
201	4	4	5	5	5	4	5	5	5	4	4	5	5	4
202	5	5	4	4	4	4	4	4	4	4	4	4	5	4
203	4	4	4	4	4	5	5	4	5	5	5	5	5	5
204	4	4	5	5	5	4	5	5	4	4	4	4	5	4
205	4	4	5	5	4	5	4	4	4	4	4	4	4	4
206	4	5	5	5	5	5	4	4	4	4	4	5	5	4
207	5	5	4	4	4	5	5	5	5	5	5	5	5	5
208	4	4	5	4	5	4	5	5	5	4	5	4	5	5
209	4	4	4	4	5	4	5	5	4	4	4	4	4	4
210	5	5	4	4	4	4	4	4	4	4	4	4	4	4
211	4	4	4	4	5	5	4	4	5	5	4	4	4	4
212	5	4	5	4	4	4	4	4	4	4	4	4	4	4
213	5	4	4	4	5	5	4	4	5	5	4	4	4	4
214	5	4	4	4	4	4	4	4	4	5	4	4	4	4
215	4	4	5	5	5	4	5	5	5	5	5	4	4	4
216	4	4	4	5	5	5	4	4	4	5	4	4	4	4
217	4	4	5	4	4	4	4	4	4	4	4	4	4	4
218	4	5	5	4	4	4	4	4	5	5	4	5	4	4
219	5	4	5	4	5	5	5	5	5	5	5	4	4	4
220	5	5	4	4	5	5	4	5	4	5	5	4	4	4
221	5	5	4	4	5	5	4	4	4	4	4	5	4	4
222	5	4	4	4	4	4	4	4	4	4	4	5	4	4
223	4	4	5	5	4	4	5	5	4	4	4	5	4	4
224	5	4	4	4	4	4	4	4	4	4	4	4	4	4

NO	KINERJA KARYAWAN													
	Kualitas kerja		Efisiensi		Kemampuan Karyawan		Ketepatan waktu		Pengetahuan Karyawan		Kreatifitas		Mengikuti Prosedur	
	Y.2.1	Y.2.1	Y.2.3	Y.2.4	Y.2.5	Y.2.6	Y.2.7	Y.2.8	Y.2.9	Y.2.10	Y.2.11	Y.2.12	Y.2.13	Y.2.14
225	4	4	5	5	5	4	5	5	4	4	4	4	4	4
226	4	4	4	4	4	4	4	5	4	4	4	4	4	4
227	5	5	5	4	5	5	5	5	5	4	4	4	4	4
228	4	5	5	5	4	4	4	5	4	4	4	4	4	4
229	5	4	4	4	4	4	4	4	4	4	4	4	4	4
230	5	4	4	4	4	4	5	5	4	4	5	4	5	5
231	5	4	5	5	5	5	5	5	5	4	4	4	5	4
232	4	4	5	5	5	4	4	5	5	4	4	4	5	4
233	4	4	5	5	4	4	4	4	4	4	4	4	5	4
234	4	4	4	4	4	4	4	4	4	4	5	5	5	4
235	4	4	4	5	5	4	5	5	4	4	5	4	5	4
236	4	4	4	5	4	5	4	4	4	4	4	4	4	4
237	4	4	4	5	5	4	5	5	5	4	4	4	5	4
238	5	4	4	4	4	4	4	4	4	4	4	5	5	4
239	4	4	4	4	4	5	5	4	5	5	5	5	5	5
240	4	4	4	4	5	4	5	5	4	4	4	4	5	4
241	5	5	4	5	4	5	4	4	4	4	4	4	4	4
242	4	5	5	4	5	5	4	4	4	4	4	4	5	4
243	5	4	4	5	4	5	5	5	5	5	5	5	5	5
244	5	4	4	4	5	4	5	5	5	4	5	4	5	5
245	5	4	4	5	5	4	5	5	4	4	4	4	4	4
246	4	4	5	5	4	4	4	4	4	4	4	4	4	4
247	4	4	5	4	4	4	5	4	4	4	4	4	5	5
248	4	4	4	4	5	4	5	5	4	4	4	4	4	5
249	4	4	4	5	4	5	4	4	4	4	4	4	5	4
250	5	4	4	5	4	4	4	5	4	4	4	4	4	5

LAMPIRAN 3

STATISTIK DESKRIPTIF

Jenis Kelamin

		Frequency	Percent	Valid Percent	Cumulative Percent
Valid	laki-laki	78	61.4	61.4	61.4
	perempuan	49	38.6	38.6	100.0
	Total	127	100.0	100.0	

pendidikan

		Frequency	Percent	Valid Percent	Cumulative Percent
Valid	SD	1	.8	.8	.8
	SMP/ sederajad	8	6.3	6.3	7.1
	SMA/ Sederajad	16	12.6	12.6	19.7
	D1	22	17.3	17.3	37.0
	D3	59	46.5	46.5	83.5
	S1	21	16.5	16.5	100.0
	Total	127	100.0	100.0	

LAMPIRAN 4

UJI REALIBILITAS DAN UJI KONFIRMATORI VARIABEL

Variabel Kinerja

	Estimate
x13 <--- kualiat	.520
xi2 <--- kualiat	.643
x11 <--- kualiat	.614
x22 <--- efisien	.530
x21 <--- efisien	.619
x33 <--- kemampuan	.592
x32 <--- kemampuan	.563
x31 <--- kemampuan	.507
x42 <--- ketepatan	.691
x41 <--- ketepatan	.776
x52 <--- pengetahuan	1.137
x51 <--- pengetahuan	.586
x62 <--- kreativitas	.736
x61 <--- kreativitas	.845
x72 <--- prosedur	.800
x71 <--- prosedur	.975
x23 <--- efisien	.072
x43 <--- ketepatan	.095
x53 <--- pengetahuan	.131
x63 <--- kreativitas	.137
x73 <--- prosedur	.224

Sumber: Data diolah peneliti 2014

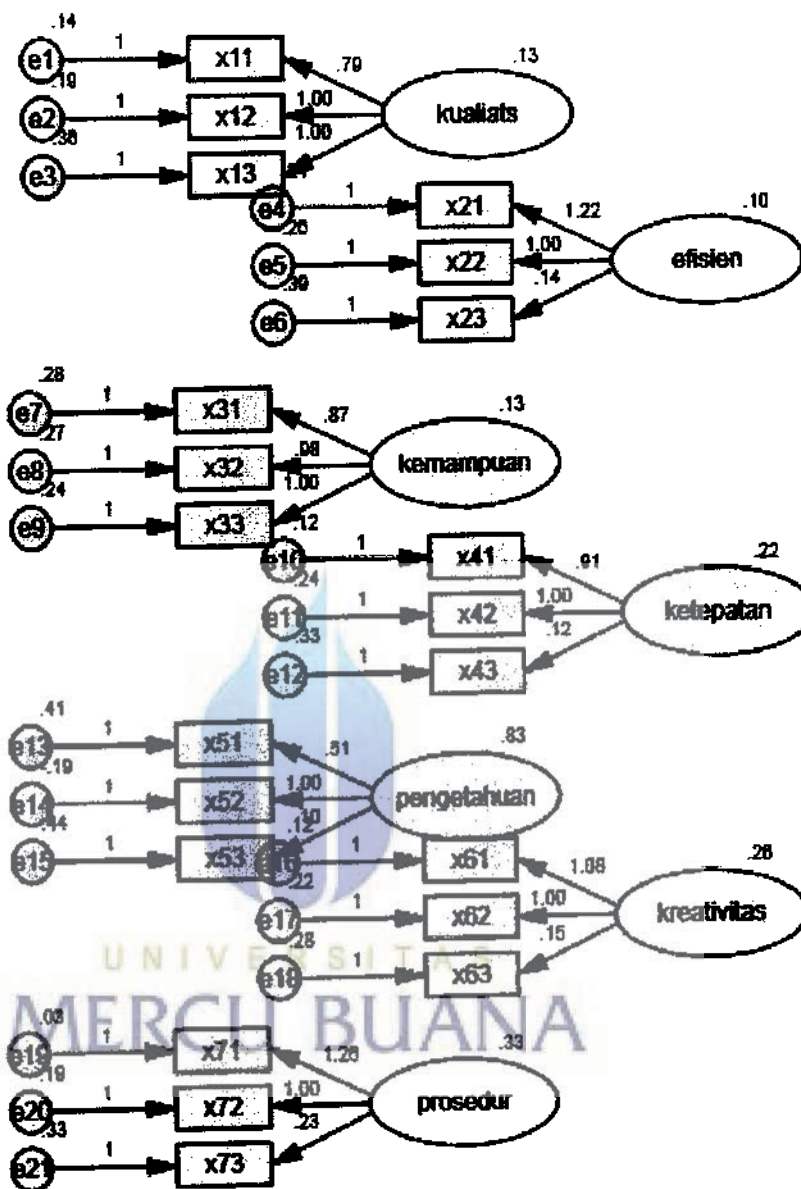

Dimensi		Loading Faktor	Error	Sqrt Loading Factor	Reliabilitas
x13	kualiats	0.52	0.361	3.16	0.82
x12	kualiats	0.643	0.19		
x11	kualiats	0.614	0.138		
Total		1.777	0.689		
x22	efisien	0.53	0.261	1.32	0.72
x21	efisien	0.619	0.243		
Total		1.149	0.504		
x33	kemampuan	0.592	0.241	2.76	0.78
x32	kemampuan	0.563	0.269		
x31	kemampuan	0.507	0.282		
Total		1.662	0.792		
x42	ketepatan	0.691	0.241	2.15	0.86
x41	ketepatan	0.776	0.122		
Total		1.467	0.363		
x52	pengetahuan	1.137	-0.189	2.97	0.93
x51	pengetahuan	0.586	0.415		
Total		1.723	0.226		
x62	kreativitas	0.736	0.216	2.50	0.88
x61	kreativitas	0.845	0.12		
Total		1.581	0.336		
x72	prosedur	0.8	0.188	3.15	0.94
x71	prosedur	0.975	0.028		
Total		1.775	0.216		

Sumber: Data diolah peneliti 2014

Variabel Budaya Organisasi

	Estimate
x14 <--- keterlibatan	.477
x13 <--- keterlibatan	.598
x12 <--- keterlibatan	.628
x11 <--- keterlibatan	.730
x26 <--- Konsisten	.713
x25 <--- Konsisten	.872
x24 <--- Konsisten	.858
x23 <--- Konsisten	.468
x22 <--- Konsisten	.789
x21 <--- Konsisten	.788
x36 <--- Adaptibilitas	.626
x35 <--- Adaptibilitas	.540
x34 <--- Adaptibilitas	.682
x33 <--- Adaptibilitas	.735
x32 <--- Adaptibilitas	.790
x31 <--- Adaptibilitas	.783
x45 <--- Misi	.736
x44 <--- Misi	.813
x43 <--- Misi	.794
x42 <--- Misi	.857
x41 <--- Misi	.731

Sumber: Data diolah peneliti 2014

MERCU BUANA

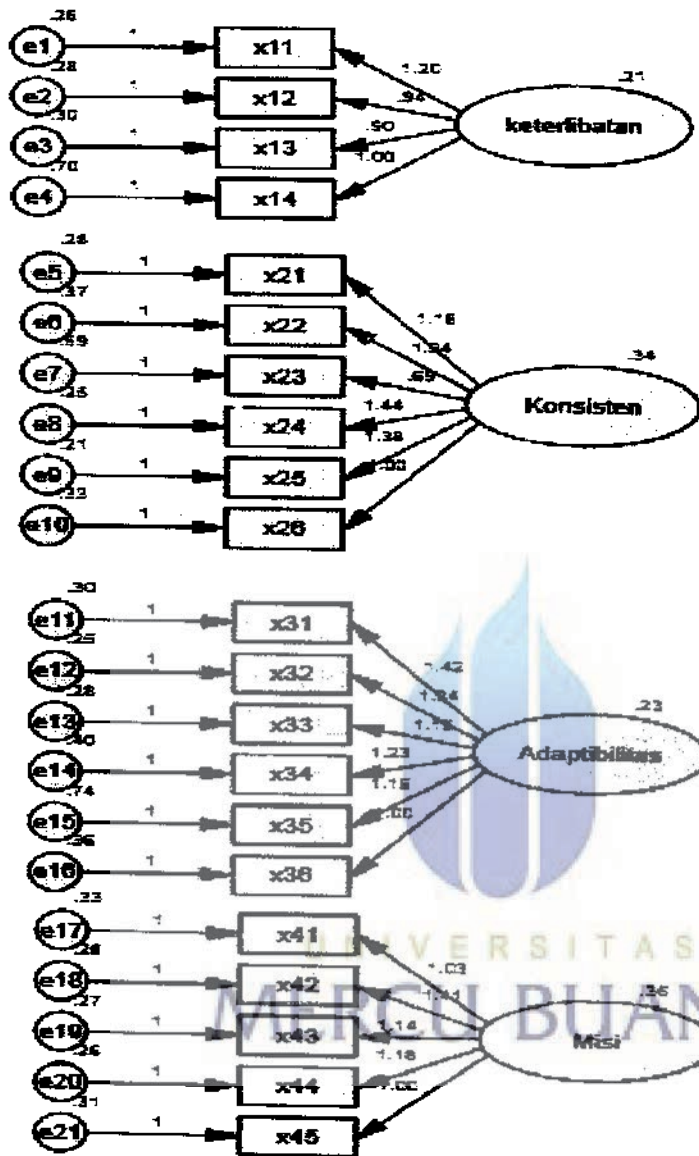

Dimensi		Loading Faktor	Error	Sqrt Loading Factor	Reliabilitas
x13	keterlibatan	0.598	0.298	3.83	0.82
x12	keterlibatan	0.628	0.282		
x11	keterlibatan	0.73	0.261		
Total		1.956	0.841		
x26	Konsisten	0.713	0.333	16.16	0.92
x25	Konsisten	0.872	0.208		
x24	Konsisten	0.858	0.254		
x22	Konsisten	0.789	0.373		
x21	Konsisten	0.788	0.284		
Total		4.02	1.452		
x36	Adaptibilitas	0.626	0.36	17.27	0.88
x35	Adaptibilitas	0.54	0.74		
x34	Adaptibilitas	0.682	0.405		
x33	Adaptibilitas	0.735	0.278		
x32	Adaptibilitas	0.79	0.252		
x31	Adaptibilitas	0.783	0.296		
Total		4.156	2.331		
x45	Misi	0.736	0.306	15.45	0.91
x44	Misi	0.813	0.258		
x43	Misi	0.794	0.275		
x42	Misi	0.857	0.264		
x41	Misi	0.731	0.333		
Total		3.931	1.436		

Sumber: Data diolah peneliti 2014

Variabel Kepemimpinan Transformasional

	Estimate
x14 <--- behavioral	.838
x13 <--- behavioral	.852
x12 <--- behavioral	.721
x11 <--- behavioral	.607
x24 <--- atributed	.682
x23 <--- atributed	.755
x22 <--- atributed	.831
x21 <--- atributed	.647
x33 <--- inspirasional	.729
x32 <--- inspirasional	.893
x31 <--- inspirasional	.794
x43 <--- intelektual	.805
x42 <--- intelektual	.850
x41 <--- intelektual	.659
x53 <--- pertimbangan	.717
x52 <--- pertimbangan	.923
x51 <--- pertimbangan	.458

Sumber: Data diolah peneliti 2014



UNIVERSITAS
MERCU BUANA

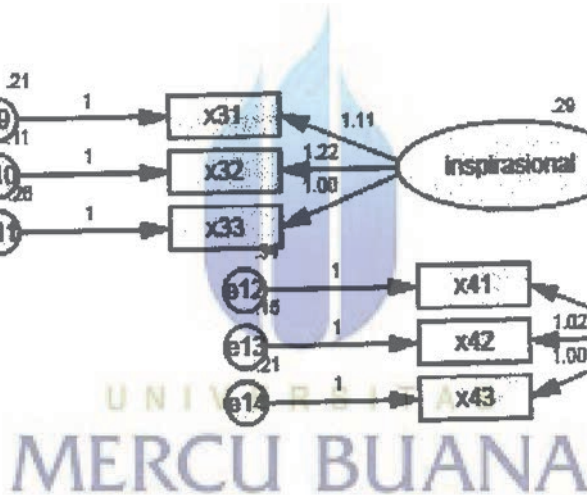
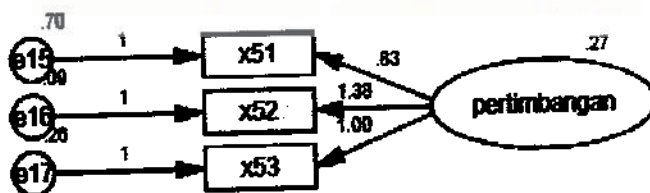
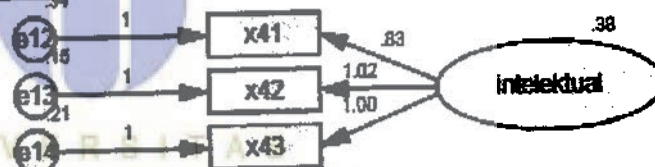
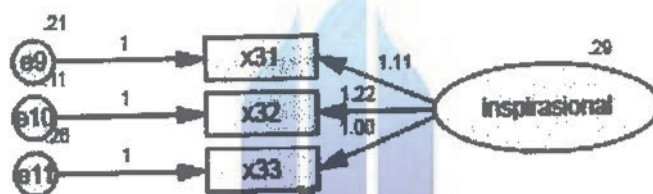
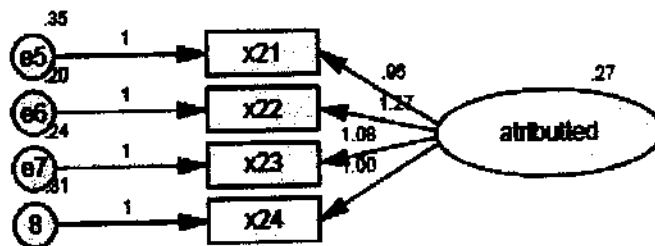
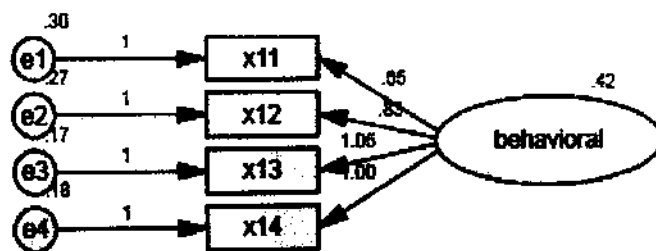

Dimensi		Loading Faktor	Error	Sqrt Loading Factor	Reliabilitas
x14	behavioral	0.838	0.179	9.11	0.91
x13	behavioral	0.852	0.175		
x12	behavioral	0.721	0.267		
x11	behavioral	0.607	0.302		
		3.018	0.923		
x24	atributed	0.682	0.314	8.50	0.89
x23	atributed	0.755	0.238		
x22	atributed	0.831	0.197		
x21	atributed	0.647	0.349		
		2.915	1.098		
x33	inspirasional	0.729	0.258	5.84	0.91
x32	inspirasional	0.893	0.11		
x31	inspirasional	0.794	0.209		
		2.416	0.577		
x43	intelektual	0.805	0.207	5.35	0.88
x42	intelektual	0.85	0.15		
x41	intelektual	0.659	0.343		
		2.314	0.7		
x53	pertimbangan	0.717	0.258	2.69	0.89
x52	pertimbangan	0.923	0.09		
		1.64	0.348		

Sumber: Data diolah peneliti 2014

Variabel Kepuasan Kerja

	Estimate
x13 <--- pekerjaan	.716
x12 <--- pekerjaan	.710
x11 <--- pekerjaan	.735
x23 <--- atasan	.462
x22 <--- atasan	.548
x21 <--- atasan	1.219
x33 <--- teman kerja	.900
x32 <--- teman kerja	.927
x31 <--- teman kerja	.875
x43 <--- promosi	.892
x42 <--- promosi	.841
x41 <--- promosi	.941
x53 <--- gaji	.856
x52 <--- gaji	.868
x51 <--- gaji	.838
x63 <--- lingkungan	.747
x62 <--- lingkungan	.949
x61 <--- lingkungan	.854

Sumber: Data diolah peneliti 2014

UNIVERSITAS
MERCU BUANA

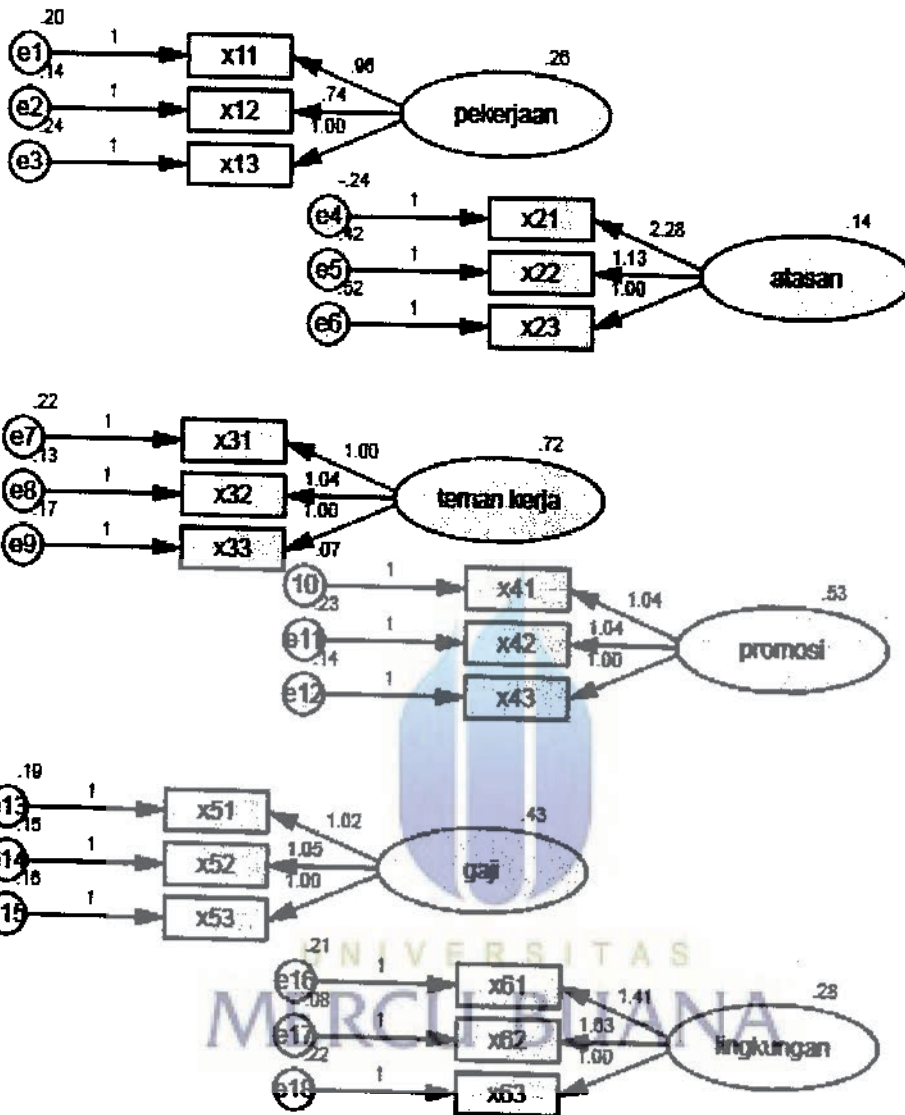

Dimensi		Loading Faktor	Error	Sqrt Loading Factor	Reliabilitas
x13	pekerjaan	0.716	0.244	4.67	0.89
x12	pekerjaan	0.71	0.138		
x11	pekerjaan	0.735	0.202		
Total		2.161	0.584		
x22	atasan	0.548	0.42	3.12	0.89
x21	atasan	1.219	-0.24		
Total		1.767	0.18		
x33	teman kerja	0.9	0.169	7.30	0.93
x32	teman kerja	0.927	0.129		
x31	teman kerja	0.875	0.219		
Total		2.702	0.517		
x43	promosi	0.892	0.135	7.15	0.94
x42	promosi	0.841	0.234		
x41	promosi	0.941	0.073		
Total		2.674	0.442		
x53	gaji	0.856	0.158	6.56	0.93
x52	gaji	0.868	0.158		
x51	gaji	0.838	0.191		
Total		2.562	0.507		
x63	lingkungan	0.747	0.222	6.50	0.93
x62	lingkungan	0.949	0.081		
x61	lingkungan	0.854	0.207		
Total		2.55	0.51		

Sumber: Data diolah peneliti 2014

LAMPIRAN 5

UJI NORMALITAS DATA DAN UJI *GOODNESS OF FIT*

Variable	min	max	skew	c.r.	kurtosis	c.r.
KER7	6.000	10.000	-.194	-1.032	-1.109	-2.952
KER6	6.000	10.000	.546	2.909	-.571	-1.519
KER5	4.000	10.000	-.017	-.091	-.999	-2.659
KER4	6.000	10.000	-.063	-.333	-.607	-1.616
KER3	9.000	15.000	-.295	-1.571	-.328	-.872
KER2	6.000	10.000	-.200	-1.066	-.226	-.601
KER1	9.000	15.000	.266	1.414	-.395	-1.053
KK1	8.000	15.000	-.170	-.903	.562	1.495
KK2	4.000	10.000	-.243	-1.296	1.075	2.861
KK3	6.000	15.000	-.319	-1.698	-.571	-1.519
KK4	6.000	15.000	.115	.611	-.105	-.278
KK5	6.000	15.000	-.272	-1.450	-.225	-.599
KK6	8.000	15.000	-.323	-1.717	-.786	-2.092
GKT1	8.000	18.000	-.819	-4.360	.257	.685
GKT2	8.000	20.000	-.604	-3.214	1.765	4.696
GKT3	6.000	15.000	.052	.277	.587	1.562
GKT4	6.000	15.000	-.330	-1.755	.826	2.197
GKT5	4.000	10.000	-.567	-3.020	.394	1.048
BO1	6.000	15.000	-.421	-2.240	1.193	3.176
BO2	10.000	24.000	-.117	-.622	-.882	-2.348
BO3	12.000	28.000	-.412	-2.193	.248	.661
BO4	10.000	24.000	-.748	-3.981	.132	.351
Multivariate					103.247	20.713

Sumber: Data diolah peneliti 2014

Goodness of fit index	Kriteria	Cut of value	Keterangan
Chi-square	Harus kecil	150,859	fit
Significant Probability	$\geq 0,05$	0,057	fit
RMSEA	$\leq 0,08$	0,035	fit
GFI	0 sampai 1	0,925	Fit
AGFI	$\geq 0,90$	0,849	Tidak fit
CMIN / DF	$\leq 2,00$	1,207	Fit
TLI	$\geq 0,90$	0,982	Fit
CFI	$\geq 0,90$	0,990	Fit
NFI	$\geq 0,90$	0,947	Fit
CFI	$\geq 0,90$	0,990	Fit
RFI	$\geq 0,90$	0,902	Fit
IFI	$\geq 0,90$	0,990	Fit
PRATIO	0 sampai 1	0,541	fit
PNFI	0 sampai 1	0,512	fit
PCFI	0 sampai 1	0,536	fit
ECFI	Diantara saturated dan independent model	2,407	fit

Sumber: Data diolah peneliti 2014

LAMPIRAN 6

UJI FULL SEM & UJI PENGARUH

Uji Full SEM

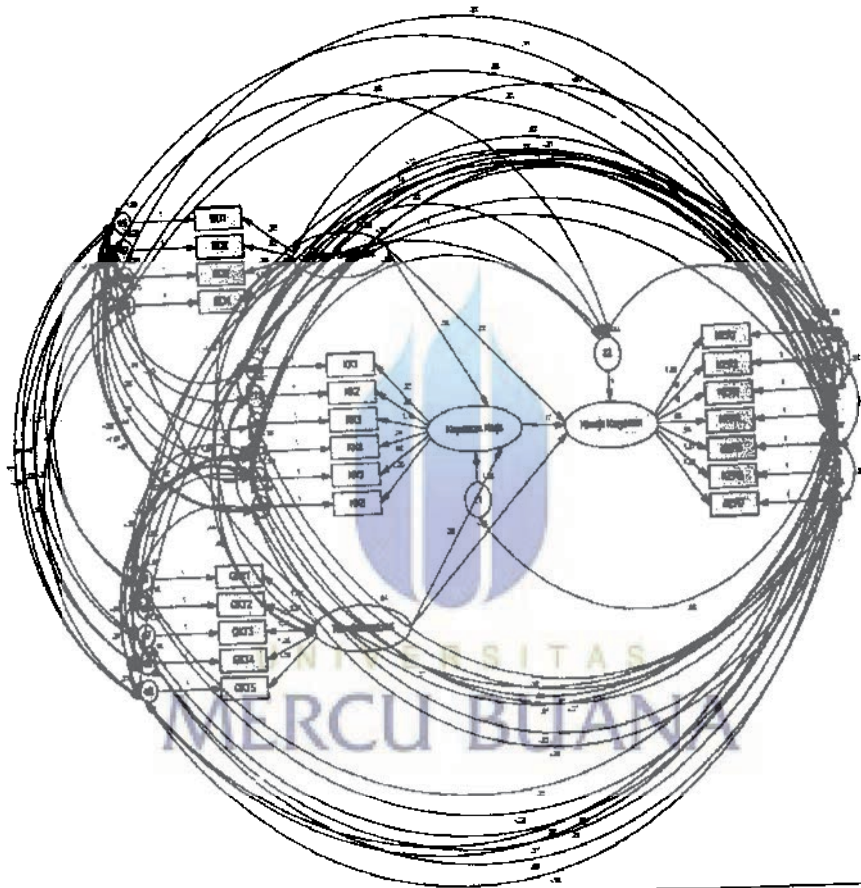

Uji Pengaruh

		Estimate	S.E.	C.R.	P	Label
Kepuasan Kerja	← Budaya Organisasi	.381	.041	9.258	***	par_19
Kepuasan Kerja	← Transformasional	.315	.136	2.314	.021	par_20
Kinerja Karyawan	← Kepuasan Kerja	.170	.063	2.701	.007	par_21
Kinerja Karyawan	← Budaya Organisasi	.081	.033	2.451	.014	par_22
Kinerja Karyawan	← Transformasional	-.215	.078	-2.755	.006	par_23

Uji Pengaruh Langsung

	Transformasional	Budaya Organisasi	Kepuasan Kerja	Kinerja Karyawan
Kepuasan Kerja	.160	.715	.000	.000
Kinerja Karyawan	-.244	.341	.380	.000

Uji Pengaruh Tidak Langsung

	Transformasional	Budaya Organisasi	Kepuasan Kerja	Kinerja Karyawan
Kepuasan Kerja	.160	.715	.000	.000
Kinerja Karyawan	-.244	.341	.380	.000



UNIVERSITAS
MERCU BUANA